

MACHINES

APF VIBRATORY PLATES

APF SERIES FORWARD MOVING
VIBRATORY PLATES



AMMANN

“ Ammann APF Plates set new standards when it comes to performance, reliability and operator comfort.”



THE RIGHT FIT ON YOUR JOBSITE

AMMANN APF FORWARD MOVING VIBRATORY PLATES

Six forward-moving vibratory plate models provide a solution for virtually all jobsite challenges.



APF 10/33

WEIGHT: 54 kg (119 lb)
MAX. VIBRATING FREQUENCY:
100 Hz (6000 vpm)
MAX. CENTRIFUGAL FORCE:
10.5 kN (2.3 lbf)



APF 12/33

WEIGHT: 68 kg (150 lb)
MAX. VIBRATING FREQUENCY:
100 Hz (6000 vpm)
MAX. CENTRIFUGAL FORCE:
12 kN (2.7 lbf)



APF 15/40

WEIGHT: 80 kg (176 lb)
MAX. VIBRATING FREQUENCY:
100 Hz (6000 vpm)
MAX. CENTRIFUGAL FORCE:
15 kN (3.4 lbf)



APF 15/50

WEIGHT: 84 kg (185 lb)
MAX. VIBRATING FREQUENCY:
100 Hz (6000 vpm)
MAX. CENTRIFUGAL FORCE:
15 kN (3.4 lbf)



APF 20/50 PETROL

WEIGHT: 88 kg (194 lb)
MAX. VIBRATING FREQUENCY:
90 Hz (5400 vpm)
MAX. CENTRIFUGAL FORCE:
20 kN (4.5 lbf)



APF 20/50 DIESEL

WEIGHT: 106 kg (234 lb)
MAX. VIBRATING FREQUENCY:
90 Hz (5400 vpm)
MAX. CENTRIFUGAL FORCE:
20 kN (4.5 lbf)

WHAT SETS THE APF PLATES APART?



PRODUCTIVITY

Large exciter unit

Boosts power, speed, climbing ability and machine life.

Toolless mountable water tanks

Enable simple refilling.

Toolless mountable rubber mats

Provide quick changes when it's time for a new application.

ERGONOMICS

Low HAV levels (below 2.5 m/sec²)

Protect the operator from unwanted vibration.

Quick and easy mounting of options (water tank, Vulcolan mat, transport wheels)

Make the most of operator and machine time.

Machine frame that enables secure grip

Helps the operator control the machine, even in difficult spaces and confined areas.

SERVICEABILITY

Maintenance-free exciter system

Reduces wear and maintenance costs.

Full engine frame

Protects against damage on the jobsite or during transport.

Toolless daily maintenance

Fast and convenient for optimal uptime.

APPLICATIONS

- Compaction in confined areas
- Light to medium patchwork
- Landscaping and gardening
- Asphalt and paving applications
- Pipeline and trench construction
- Earthwork

TECHNICAL ADVANCED

THE EXTRA BENEFIT FOR YOUR SUCCESS

Technology and innovative design are the driving forces behind the durability, productivity and operator comfort built into every Ammann forward-moving vibratory plate.



RELIABLE POWER

The APF line is powered by reliable and efficient Honda petrol engines. The APF 20/50 is available with a petrol or a Hatz diesel engine, which performs well in high altitudes and enables the use of a single fuel type on many jobsites. The sturdy protection frame on all engines prevents damage during operation or transport, and ultimately extends plate life.

MAINTENANCE-FREE EXCITER SYSTEM

A generously sized exciter unit provides the industry-leading forward movement, speed and climbing ability. The long-lasting, optimized ball bearing unit is sealed, blocking entry of air or water and eliminating the need for service.



SELF CLEANING BASE PLATE

The design of the base plates automatically moves loose material off the plate during compaction work. This helps to keep the machine clear and prevents loose material to get stuck between machine components.

WEAR OPTIMISED BASE PLATE

The plates perform in a variety of materials, from abrasive aggregates to clays. The bottom wear plate is designed to last, with thicker protection toward the back of the plate where the most wear occurs.

THE ERGONOMICS LEADER

A JOY TO WORK WITH

Ammann APF plates are at the top of the class when it comes to operator safety and ergonomics. The plates offer the reliability and precise control necessary to overcome changing jobsite challenges. Intuitive operation helps plate operators of all experience levels succeed.



REDUCES UNWANTED VIBRATION

Ammann plates lead the industry in lowest hand-arm vibration (HAV) levels. In fact, the levels are so minimal that the machines will remain in compliance with the strictest regulations for many years to come. The reduced vibration values (below 2.5 m/sec²) result from the Z-buffer in the handle bar. This patented system enables long work shifts without health risk to the operator or a need for documentation.

For simple transportation the handle can be folded down over the machine.



HIGHLY MANOEUVRABLE

The powerful forward movement of the plates boosts productivity and enables consistent results, even on steep grades. The base plate is designed to add forward-moving efficiency. The handle and grip nearer the base plate help the operator manoeuvre the compactor in tight spaces.



EASY TRANSPORT

A central, easy-to-grip transport hook makes it simple to lift the plate while loading it into a vehicle or removing it from trenches. The plate is small enough to fit into a vehicle of any size.

OPTIONAL EQUIPMENT

BRINGING FLEXIBILITY FOR YOUR NEEDS

Quick-change options enhance versatility and ensure the machines are precisely matched for the jobsite. The options include a rubber mat for working on paving stones and a water sprinkling system for asphalt applications.



WATER SPRINKLING SYSTEM

The tank and sprinkler are combined into a single unit that can be added or removed without any tools, or even adjustment of a single screw. The sprinklers provide comprehensive surface coverage and can be activated by simply turning a switch. The 10-litre tanks extend intervals between fillings.



PERMANENTLY INSTALLED TRANSPORT WHEELS

The transport wheels can be dropped with a foot release, preventing fingers from being pinched and reducing stress on the operator's back. The high quality wheels are durable and enable quick and easy transport around the jobsite.



HOUR METER

The plates can be fitted with hour meters to help monitor maintenance needs.



TOOLLESS MOUNTABLE RUBBER MAT

This optional mat can be mounted in a few seconds, preparing the machine for work on paving stones and protecting the stones' edges from cracking. Installation is extremely easy: The mat wraps around the foot and is secured with two hooks.

APF 10/33

FORWARD MOVING VIBRATORY PLATE

SUPERIOR MOBILITY AND PERFORMANCE

The APF 10/33 is the lightest and smallest vibratory plate from Ammann. Its compact size makes it ideally suited to small jobsites and confined areas.

This forward moving vibratory plate compactor is often used by landscape contractors to reach hard-to-access spots. The APF 10/33 is also popular with home-owners because of its manageable size.

The standard, low-vibration guide handle improves operator comfort. When the work is done, the compactor is small enough to fit in the boot of a car.



HIGHLIGHTS

- Well-protected, robust centrifugal clutch with wear-resistant V belt
- Maintenance-friendly exciter with a long life-span
- Powerful petrol engine
- Wear-resistant, self-cleaning base plate
- Optional water sprinkler system for work on bituminous surfaces



APF 12/33

FORWARD MOVING VIBRATORY PLATE



INDUSTRY-LEADING COMPACTION

The APF 12/33 is an outstanding match for soils and soft bases, particularly those associated with gardening and landscaping. It has a working width of 330 mm and engine power of 2.9 kW (4 HP). The plate's technologically advanced exciter unit is maintenance free, with cylindrical bearings that reduce wear. The exciter system also provides significant forward-moving power to enhance productivity in challenging materials and on steep grades.

Versatility is a key benefit of all Ammann APF plates. An optional Vulcolan mat, which can be installed without a single tool, provides quick adjustment when working with paving stones. A sprinkling system enables work on asphalt.

Ammann plates lead the industry in lowest hand-arm vibration (HAV) levels. The levels are so minimal that the machines will remain in compliance with the strictest regulations for many years to come.

HIGHLIGHTS

- Low-vibration handle for operator safety and comfort
- Maintenance-free exciter system
- Base plate that is self cleaning and wear resistant
- Engine frame for protection on the jobsite and during transport



APF 15/40

FORWARD MOVING VIBRATORY PLATE



BROAD APPLICATION RANGE

The APF 15/40 is able to utilise key options to make this forward-moving plate extremely versatile. An optional Vulcolan mat, which can be installed without a single tool, provides quick adjustment when working with paving stones. A sprinkling system enables work on asphalt. The plate features a working width of 400 mm and engine power of 2.9 kW (4 HP).

The plate's technologically advanced exciter unit is maintenance free, with cylindrical bearings that reduce wear. The exciter system also provides significant forward-moving power to enhance productivity in challenging materials and on steep grades.

Ammann plates lead the industry in lowest hand-arm vibration (HAV) levels. The levels are so minimal that the machines will remain in compliance with the strictest regulations for many years to come.

HIGHLIGHTS

- Low-vibration handle for operator safety and comfort
- Maintenance-free exciter system
- Base plate that is self cleaning and wear resistant
- Engine frame for protection on the jobsite and during transport
- Transport wheels, which can be dropped with a foot release and enable mobility on the jobsite



APF 15/50

FORWARD MOVING VIBRATORY PLATE

COMFORT AND OUTPUT

The APF 15/50 combines the powerful Ammann exciter system with industry-leading low hand-arm vibration (HAV) levels. The result is a powerful compactor that's comfortable and safe for operators, too. The plate features a working width of 500 mm and engine power of 2.9 kW (4 HP).

The plate's technologically advanced exciter unit is maintenance free. The exciter system also provides significant forward-moving power to enhance productivity in challenging materials and on steep grades.

The APF 15/50 is able to utilise key options to make this forward-moving plate extremely versatile. An optional Vulcolan mat, which can be installed without a single tool, provides quick adjustment when working with paving stones. A sprinkling system enables work on asphalt.



HIGHLIGHTS

- Low-vibration handle for operator safety and comfort
- Maintenance-free exciter system
- Base plate that is self cleaning and wear resistant
- Engine frame for protection on the jobsite and during transport
- Transport wheels, which can be dropped with a foot release and enable mobility on the jobsite



APF 20/50

FORWARD MOVING VIBRATORY PLATE

PACKING POWER

The APF 20/50 provides the most power in the new APF lineup. It features a working width of 500 mm and centrifugal force of 18 kN. The plate's technologically advanced exciter unit is maintenance free. The exciter system also provides significant forward-moving power to enhance productivity in challenging materials and on steep grades.

Ammann plates lead the industry in lowest hand-arm vibration (HAV) levels. The levels are so minimal that the machines will remain in compliance with the strictest regulations for many years to come.

The machine is versatile, too, through the use of key options. An optional Vulcolan mat, which can be installed without a single tool, provides quick adjustment when working with paving stones. A sprinkling system enables work on asphalt. The APF 20/50 Honda has an engine output of 3.7 kW (5 HP), the most power in the new APF lineup.



HIGHLIGHTS

- Low-vibration handle for operator safety and comfort
- Maintenance-free exciter system
- Base plate that is self cleaning and wear resistant
- Engine frame for protection on the jobsite and during transport
- Transport wheels, which can be dropped with a foot release and enable mobility on the jobsite

The APF 20/50 Hatz combines all the benefits of other Ammann plates with a diesel engine that makes fueling at the jobsite more convenient. The diesel engine provides engine power of 3.2 kW (4.3 HP) and also excels in higher altitudes.



“Contractors can choose a diesel or petrol engine for the APF 20/50.”



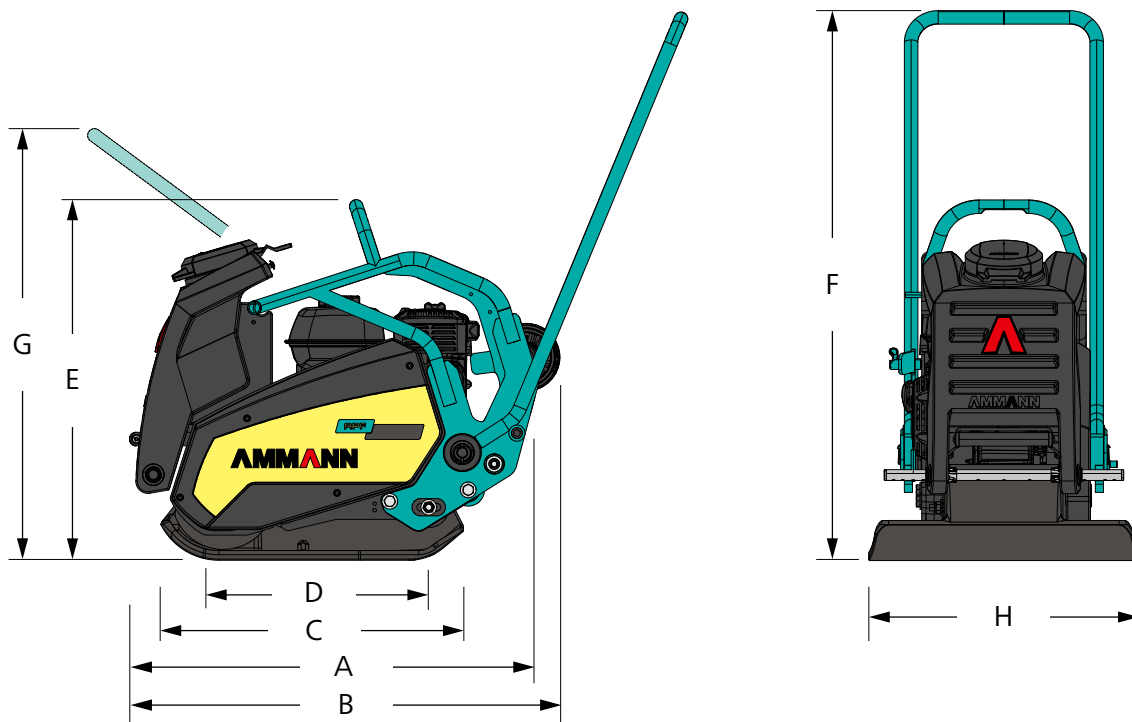

DIMENSIONS & WEIGHTS

	APF 10/33 Honda	APF 12/33 Honda	APF 15/40 Honda	APF 15/50 Honda	APF 20/50 Honda	APF 20/50 Hatz
MACHINE WEIGHT	54 kg (119 lb)	68 kg (150 lb)	80 kg (176 lb)	84 kg (185 lb)	88 kg (194 lb)	106 kg (234 lb)
MACHINE WEIGHT (INCL. OPTIONAL SPRINKLER & WHEELS)	54 kg (119 lb)	74 kg (163 lb)	89 kg (195 lb)	93 kg (204 lb)	97 kg (213 lb)	106 kg (234 lb)
A MACHINE LENGTH	1130 mm (44.5 in)	961 mm (37.8 in)	1020 mm (40.2 in)	1020 mm (40.2 in)	1020 mm (40.2 in)	1020 mm (40.2 in)
B MACHINE LENGTH (INCL. OPTIONAL SPRINKLER & WHEELS)	1130 mm (44.5 in)	1018 mm (40.1 in)	1075 mm (42.3 in)	1075 mm (42.3 in)	1075 mm (42.3 in)	1075 mm (42.3 in)
C BASE PLATE LENGTH	497 mm (19.6 in)	559 mm (22.0 in)	559 mm (22.0 in)	559 mm (22.0 in)	559 mm (22.0 in)	559 mm (22.0 in)
D GROUND CONTACT LENGTH	341 mm (13.4 in)	352 mm (13.9 in)	352 mm (13.9 in)	352 mm (13.9 in)	352 mm (13.9 in)	352 mm (13.9 in)
E MACHINE HEIGHT	453 mm (17.8 in)	488 mm (19.2 in)	667 mm (26.3 in)	667 mm (26.3 in)	667 mm (26.3 in)	674 mm (26.5 in)
F WITH HANDLE (WORK)	932 mm (36.7 in)	993 mm (39.1 in)	976 mm (38.4 in)	976 mm (38.4 in)	976 mm (38.4 in)	976 mm (38.4 in)
G WITH HANDLE (TRANSPORT)	1100 mm (43.3 in)	1088mm (42.8in)	736 mm (29.0 in)	736 mm (29.0 in)	736 mm (29.0 in)	736 mm (29.0 in)
H MACHINE WIDTH	330 mm (13.0 in)	330 mm (13.0 in)	400 mm (15.7 in)	500 mm (19.7 in)	500 mm (19.7 in)	500 mm (19.7 in)

ENGINE

ENGINE	Honda GX 120	Honda GX 120	Honda GX 120	Honda GX 120	Honda GX 160	Hatz 1B20
FUEL	Petrol	Petrol	Petrol	Petrol	Petrol	Diesel
ENGINE OUTPUT AT RPM	2.2 kW (3 HP) 3600	2.9 kW (4 HP) 3600	2.9 kW (4 HP) 3200	2.9 kW (4 HP) 3600	3.7 kW (5 HP) 3250	3.2 kW (4.3 HP) 3250

COMPACTION FORCES

MAX. VIBRATION FREQUENCY	100 Hz (6000 vpm)	100 Hz (6000 vpm)	100 Hz (6000 vpm)	100 Hz (6000 vpm)	90 Hz (5400 vpm)	90 Hz (5400 vpm)
MAX. CENTRIFUGAL FORCE	10.5 kN (2.3 lbf)	12 kN (2.7 lbf)	15 kN (3.4 lbf)	15 kN (3.4 lbf)	20 kN (4.5 lbf)	20 kN (4.5 lbf)
WORKING SURFACE	0.11 m ² (170.5 in ²)	0.12 m ² (186.0 in ²)	0.14 m ² (217.0 in ²)	0.18 m ² (279.0 in ²)	0.18 m ² (279.0 in ²)	0.18 m ² (279.0 in ²)
SPEC. SURFACE PRESSURE	9.3 N/cm ² (15.4 lbf/in ²)	10.3 N/cm ² (15.0 lbf/in ²)	10.7 N/cm ² (15.5 lbf/in ²)	8.5 N/cm ² (12.4 lbf/in ²)	10.2 N/cm ² (14.8 lbf/in ²)	10.2 N/cm ² (14.8 lbf/in ²)

“Proven technology and years of experience are reflected in every model of the APF range.”



MISCELLANEOUS

	APF 10/33 Honda	APF 12/33 Honda	APF 15/40 Honda	APF 15/50 Honda	APF 20/50 Honda	APF 20/50 Hatz
HAND-ARM VIBRATION ON HANDLE	-	< 2.5 m/s ²	< 2.5 m/s ²	< 2.5 m/s ²	3.1 m/s ²	< 2.5 m/s ²
SPEED	0–22 m/min (72.2 fpm)	0–20 m/min (65.6 fpm)	0–22 m/min (72.2 fpm)	0–20 m/min (65.6 fpm)	0–27 m/min (88.6 fpm)	0–27 m/min (88.6 fpm)
GROUND COVERAGE	436 m ² /h (4693 ft ² /h)	455 m ² /h (4897 ft ² /h)	648 m ² /h (6975 ft ² /h)	720 m ² /h (7750 ft ² /h)	930 m ² /h (10010 ft ² /h)	990 m ² /h (10656 ft ² /h)
GRADEABILITY	30 %	30 %	30 %	30 %	30 %	30 %
MAX. INCLINE TO ALL SIDES	20°	20°	20°	20°	20°	20°

OPTIONS

RUBBER MAT	-	-	x	x	x	x
TRANSPORT WHEELS	-	-	x	x	x	x
WATER SPRINKLER SYSTEM	5 l	8 l	12 l	12 l	12 l	12 l
HOURLY METER	x	x	x	x	x	x

TRAINING

ENHANCE YOUR PERFORMANCE

If Ammann machine training was summarised in a single word, it might well be “comprehensive.” The training includes multiple expertise levels and modules to benefit all skill levels.

TRAINING WORLDWIDE

Ammann product and application experts are ready to provide the training you need, no matter where you are. The global nature of Ammann ensures an expert is always near you – ready to offer instruction that ranges from the basics to the specifics relevant to your geographic area. The training can take place at an Ammann facility, your business – or even on a jobsite.

KEY TEACHING THEMES CONNECT ALL EFFORTS, NO MATTER WHERE THEY OCCUR

A good balance. Training often combines a traditional classroom setting with hands-on machine experience. Ammann application experts also can offer instruction on your jobsite.

Training typically includes students from other industry businesses. Participants say conversations with their peers – and learning how they overcome challenges – are other key benefits.

Learn in your language. Lessons are taught in many languages, ensuring your team understands key terms and lessons and makes the most of your training investment.



SERVICE

A NETWORK TO SUPPORT YOU

No matter where you are, Ammann-trained technicians and parts are nearby. Ammann dealers provide well-trained service technicians who can help you, whether it's an emergency or time for preventive maintenance. The vast Ammann network ensures there is a nearby technician who understands your language and your technical needs. Parts availability and ease of ordering are always Ammann priorities.

HOTLINE SUPPORT

Ammann experts are ready to answer your technical questions 24 hours a day, seven days a week. The hotline team is highly trained and experienced. Representatives can talk you through the challenges – in various languages – to help keep your machine productive.

SERVICE APP

The service app for Ammann machines impresses machine operators who are already benefiting from the advantages of the free application. The easy-to-use app provides machine operators working on site quick and uncomplicated access to machine documentation.

SERVICE VIDEOS

Sometimes a video tells the story best. That's why you'll find a variety of service videos that walk you through service and maintenance processes.

QR CODE

Many maintenance kits feature QR codes that link to videos with helpful demonstrations that walk you or your technician through the process. The videos tell the story without dialogue so customers anywhere in the world can understand.



SPARE PARTS

You can only earn money when your equipment is working. That's why Ammann does everything possible to ensure you have the parts where and when you need them. Those efforts include easy online ordering to avoid confusion and enable tracking, and efficient logistics and availability to help parts reach you quickly.

WEARING KITS

Some machines handle abrasive materials in demanding applications. While wear is inevitable, downtime can be limited. Wearing kits make replacement of these parts efficient and cost-effective. All the necessary parts – big and small – are in a single box to keep you organised and efficient and to ensure the machines are quickly back up and running.

EMERGENCY KITS

Emergency kits prevent little frustrations from becoming bigger issues that can shut down a machine and even a jobsite. These kits include parts such as switches, fuses and valve coils that are simple and fast to change yet still can cause significant problems if not operating properly. The kits easily fit in the trunk or bed of a vehicle so they're on hand when needed. A crew-member with a bit of technical knowledge can handle this work on the jobsite. These repairs take 2 hours or less.



MAINTENANCE KITS

Preventive maintenance is crucial to efficient operation and service life of machines. The easier the maintenance, the more likely it is to be completed. Maintenance kits make the upkeep simple. Parts associated with a particular maintenance process are in a single box with a single part number.

BROCHURE WITH ALL KITS

We have a prospect with all kits, and their part numbers are available for you. Just contact your parts consultant and have a digital or hardcopy sent to you.



“Service kits ensure that every part is there when you need it, while emergency kits prevent a little challenge from becoming a big one.”



For additional product information
and services please visit:
www.ammann-group.com

