

# SUMITOMO

**SH75X-6A**  
**SH75XU-6A**  
**SH80BS-6A**

## SUMITOMO

■Motor Gücü (Net):	40.0 kW·54.4 PS
■Çalışma Ağırlığı:	
SH75X-6A .....	7,880~8,050 kg
SH75XU-6A .....	8,260~8,410 kg
SH80BS-6A .....	8,570~8,730 kg
■Kova Kapasitesi:	: 0.11~0.34 m <sup>3</sup>

**LEGEST**  
HYDRAULIC EXCAVATOR FOR REAL PERFORMANCE



 **SUMITOMO (S.H.I.)**  
**CONSTRUCTION MACHINERY CO., LTD.**

731-1 Naganumahara-cho, Inage-ku, Chiba, 263-0001 Japan  
For further information please contact: Phone : +81-43-420-1829 Facsimile : +81-43-420-1907

We are constantly improving our products and therefore reserve the right to change designs and specifications without notice.  
Illustrations may include optional equipment and accessories and may not include all standard equipment.

# Performance Refined. Evolution Defined.

## Engine and Hydraulics 04-07

- New Generation Engine System "SPACE 5+"
- New Hydraulic System "SIH:S+"
- SUMITOMO Fuel Efficiency Technology
- Dramatically Increased Productivity

## Durability and Maintenance 08-09

- High Rigidity Attachments
- EMS
- Ground Level Maintenance

## Safety and Operator Comfort 10-13

- ROPS Cabin
- Stylish and Spacious Cabin
- High-Definition Full Colour LCD Monitor

## Specifications 14-22

### MADE IN JAPAN

The world knows that Japanese designed, engineered and manufactured products represent the highest quality, especially for Industrial Products. The hydraulic excavator is no exception when a totally integrated concept is required in design work involving key components, manufacturing engineering, and product quality assurance in the factory. Sumitomo is one of the largest business groups in Japan, tracing its roots back to the late 1600's when they started a mining and copper smelting business, and since then have expanded and diversified their business operations on a continuing basis. Sumitomo hydraulic excavators are designed and manufactured today to meet the global demands of our many customers with the concept of Performance, Reliability, and Fuel Efficiency foremost in our minds. This proven Japanese technology and quality gives SUMITOMO excavator customers total peace of mind and provide a complete solution for the demands of the construction industry.

SH80BS-6A



- Fuel Consumption  
**5% Reduction**  
(in A mode compared with previous model)
- PM  
**93% Reduction**  
(as compared to Tier 3 levels)

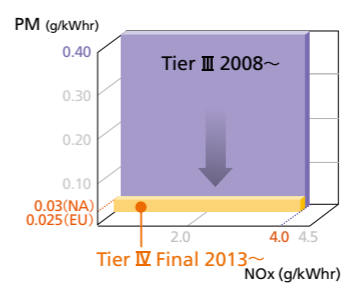

**Compliant to Emission Regulations U.S. EPA Tier 4 Final and EU Stage III B.**

The state-of-the-art engine system "SPACE 5+" substantially reduces PM (particulate matter) contained in the exhaust gas, further reducing or minimising the impact on the environment.

### New Generation Engine System "SPACE 5+"

The new engine system optimises fuel efficiency and environmental performance via the advanced common rail fuel injection system, cooled EGR system, and wastegate turbocharger. At the same time, excellent response times are achieved.

### 4LE2X Engine System Overview

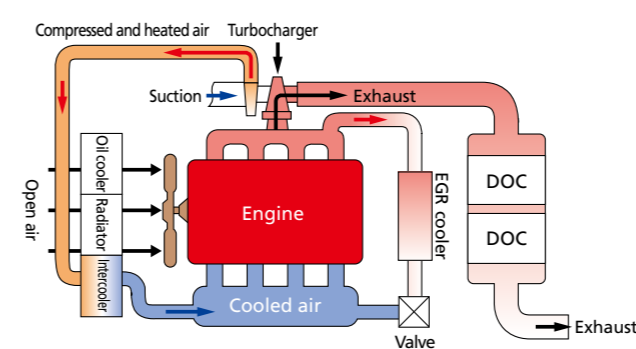

### Mode Selection by Throttle

There are three new working modes available: SP (Super Power) for heavy duty applications, H (Heavy) for normal working conditions, and A (Auto) for a wide range of operations.



### Further Improvements to Fuel Consumption

Optimal control for economic operation has reduced fuel consumption by 5% in A mode.

### ECO Gauge to Display Energy Efficiency Operation

An ECO Gauge and fuel consumption indicator are included within the monitor to make energy efficiency recognisable in an instant.



## Engine and Hydraulics



SH75X-6A has achieved a 5% reduction in fuel consumption in comparison with the previous Dash 3B series, by fusing the new generation engine system "SPACE 5+" and the new hydraulic system "SIH:S+", further refining fuel efficiency. At the same time the newly developed ISUZU engine, which complies with emission regulations such as U.S. EPA Tier 4 Final and EU Stage III B, contributes greatly to the environment.



New Engine System **SPACE 5+ PLUS** + New Hydraulic System **SIH:S+ PLUS** = **5% Reduction in Fuel Consumption**  
(as compared with the previous model)

SUMITOMO's original hydraulic system "SIH:S+" perfectly matches the engine and hydraulic power, further improving the operational speed whilst maintaining smooth control of the machine.

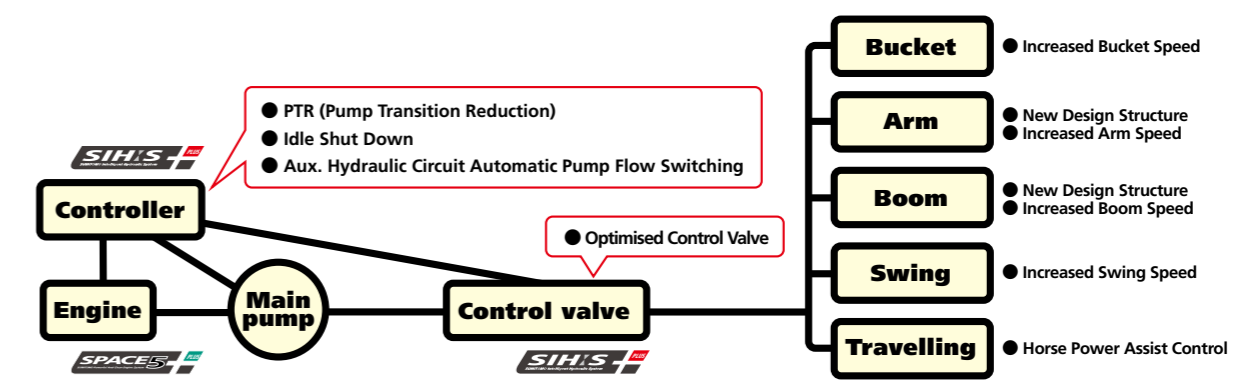

# Engine and Hydraulics

## SH75XU-6A

Mobility With Small Swing Radius and Offset Boom to Suit a Diverse Range of Jobs

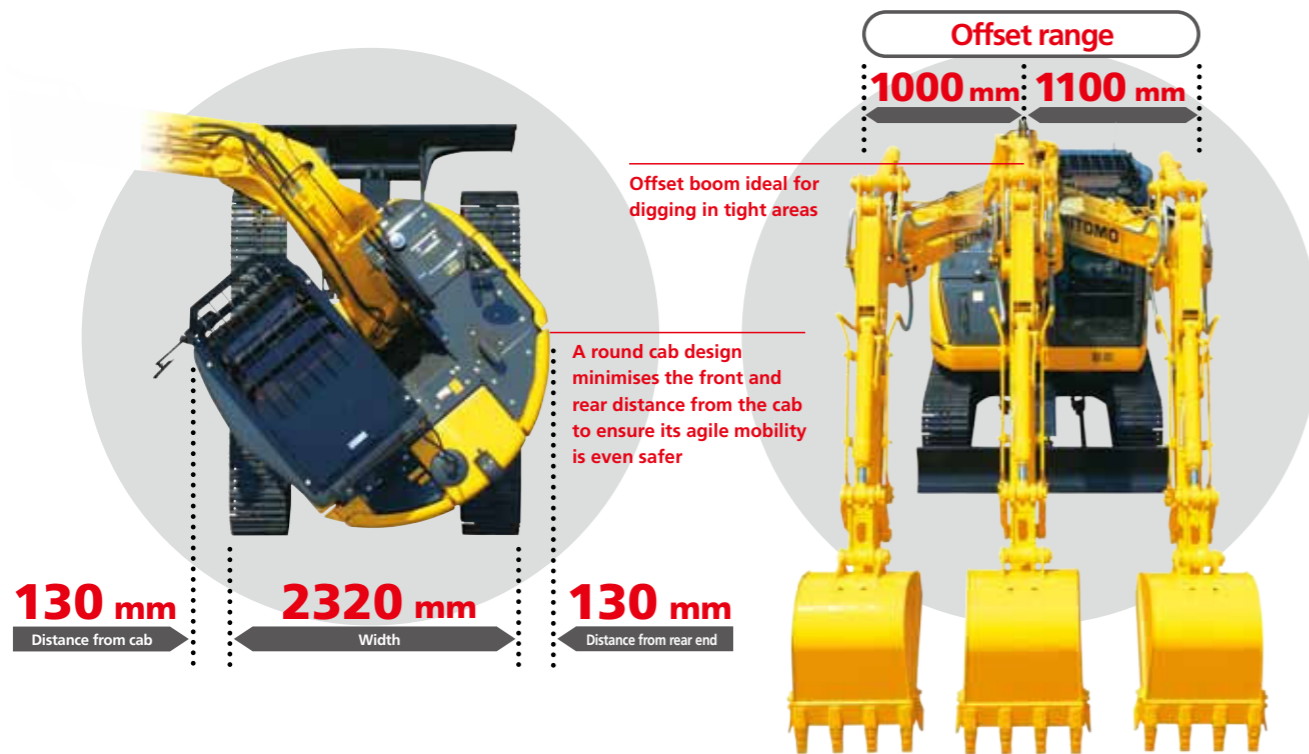

## SH80BS-6A

Mobility With Small Swing Radius and Swing Boom to Suited a Diverse Range of Jobs

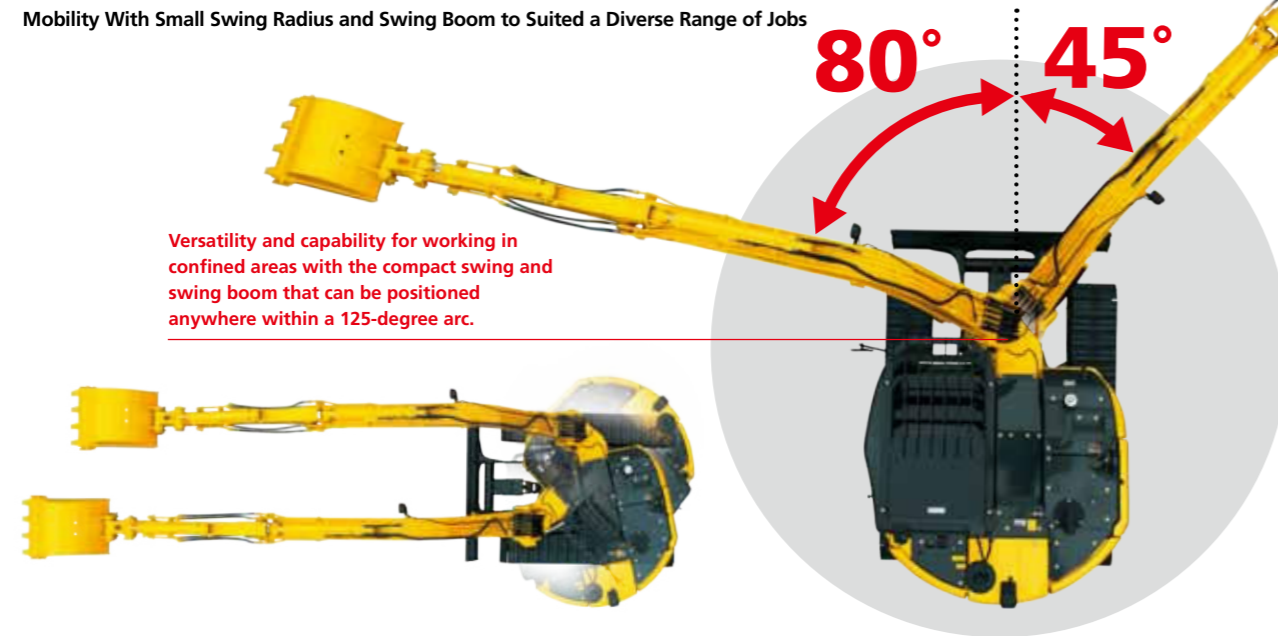

### Speed and Power, Dramatically Increases Productivity

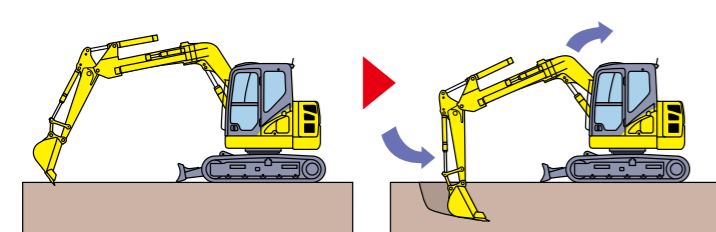

- SP mode **7%** faster cycle time
- H mode **3%** faster cycle time
- A mode **1%** faster cycle time

(as compared with the previous model)  
\*Based on SUMITOMO's testing condition and results.

### Increased Pump Flow Capacity

The volume of the main pump has been increased by 9% for faster work speed and more flexibility with complex operations.

### Shorter Cycle Time and Operability

A speed increase of 7% for cycle time (SP mode) has been achieved, compared with the previous model. Control also focuses on operability when delicate operations are required, ensuring both productivity and operability.

### PTR (Pump Transition Reduction)

PTR decreases main pump loads to reduce fuel consumption. Pressure sensors are constantly monitored to prevent engine lug-down upon abrupt pump load.

### Auxiliary Hydraulic Circuit

Selection of auxiliary circuit has been made easier. Correct pump flow (one pump or two pump) will automatically be activated upon operator's selection of the circuit.

### Auto Idle & Idle Shut Down

Auto Idle function automatically signals the engine to drop back to idle when the joysticks are at rest for more than five seconds. Idle Shut Down automatically shuts the engine down when the machine is not in operation for set amount of time.

### Operating Condition Easily Viewable on Display

Various control such as working modes and auxiliary hydraulic setting can be easily selected by the universally designed switch panel, and the selected mode can be easily viewed on the 7" wide monitor.



# Durability and Maintenance

Serviceability and durability are also important points of machine performance. Ground level access to the engine area makes daily maintenance extremely straightforward. Reliability has been further enhanced by increasing cooling capability and durability.

## EMS (Easy Maintenance System) as Standard

SUMITOMO's EMS keeps the pins and bushes fully lubricated at all times and prevents rattling. This system significantly extends the service life of the pins and bushes.

The lubrication interval around the bucket is 250 hours, and for the other sections is 1,000 hours, keeping the joints lubricated for a long time and extending the service life of parts by reducing abrasion and rattling.

- ➡ Sections equipped with steel EMS bushing
- ➡ Sections equipped with EMS bushing

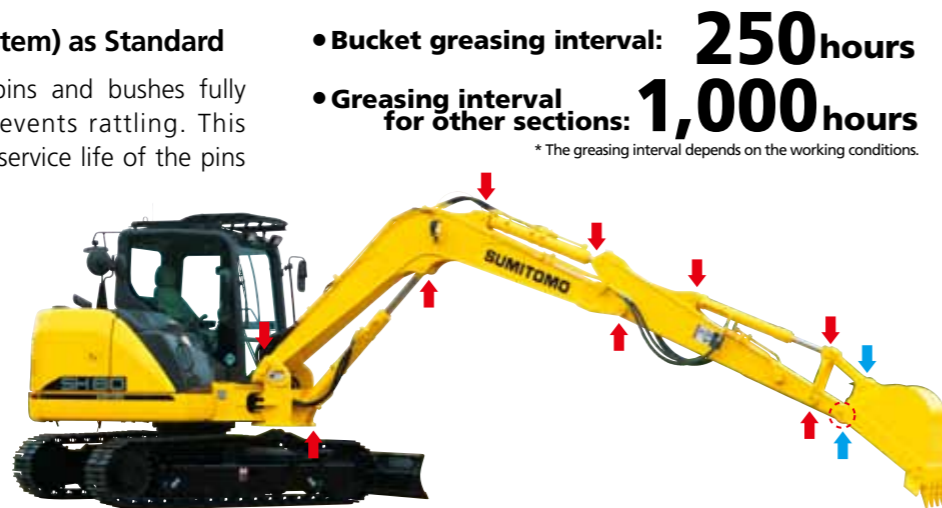

### EMS bushing

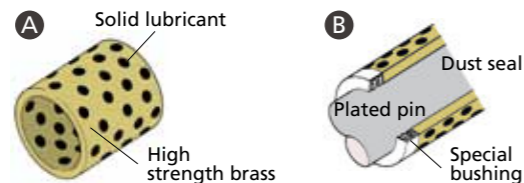

- A** A solid lubricant embedded in high strength brass forms a layer on the bushing surface to prevent contact between metals, maintaining an excellent lubricated state to reduce abrasion of joints.
- B** The surface of the pin is plated to increase the surface hardness and improve the wear resistance accordingly.

### Steel EMS bushing



Steel EMS is installed around the bucket

- Precautionary use of EMS
- ① Grease is enclosed, however greasing is necessary every 1000 hours or six months depending on the level of dusting conditions.
  - ② Greasing is also necessary after any components have been submerged underwater for prolonged periods.
  - ③ Greasing is also recommended after use with hydraulic breakers, crushers or other high impact attachments such as rock saws.
  - ④ Bucket pins should be cleaned thoroughly when removing or attaching new buckets.

## High Rigidity Attachments

The structure of the boom and arm has been further improved, ensuring strength and durability. In addition, high strength castings are used for the boom end, improving reliability.

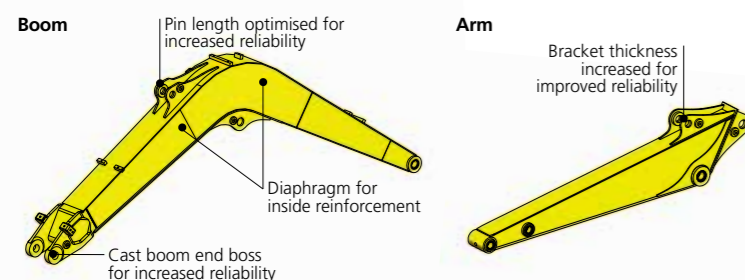

## Inner Hydraulic Hose (SH75XU-6A)

The hydraulic hose is installed inside the off-set rod, protecting it from potential damage caused by direct external contact.



## Ground Level Access to Engine Area Improves Preventative Maintenance

Parts cleaning and maintenance are possible from the ground without climbing onto the upper structure of the excavator body.

### ● Increased Cooling Capability

With the improved air flow and EGR cooler, cooling capacity is increased, thus improving reliability. In addition, cleaning of the dust-proof net is simplified.

### ● Easy Filter Replacement

A fuel prefilter and clogging sensor to the main fuel filter are provided as standard equipment to reduce trouble due to fuel clogging. In addition, the fuel and oil filters are installed at ground-accessible location to facilitate replacement.



## High-Performance Return Filter

The hydraulic oil change interval is 5,000 hours, and the return filter change interval is 2,000 hours. One high performance return filter keeps the same level of filtering as a nephron.



## Easy Access to A/C Filter

The air intake filter is located in a lockable compartment to make it easier to replace, and access to the inside cab filter has been simplified.



## ● Hydraulic oil change: 5,000 hours

## ● Life of filter: 2,000 hours

\* The oil and filter change interval varies depending on the working conditions.

## Cab Floor Mat



The washable floor mat has been redesigned for ease of removing and cleaning.



## Fuse Box Location

The fuse box has been located in a separate compartment behind the seat, allowing easier access.





## Safety and Operator Comfort

The cabin provides Roll Over Protective Structure (ROPS) in compliance with ISO 12117-2:2008. This enhanced protection comes standard from the factory.

The cabin is also compliant to OPG Top Guard Level 1.

To support the operator in the field, the DASH 6 incorporates a 7" wide full colour LCD monitor with numerous functions and universally designed switch panel.

The ROPS compliant cabin with enhanced operator comfort ensures a safe working environment.

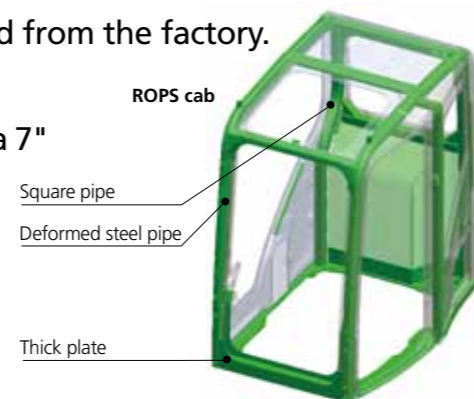

### Wide View Increases Safety of Work

In addition to the wide front view, the upper and side views have been widened to enhance work safety.

### Rearview Camera

With the optional rearview camera, the operator can view the image on the large LCD monitor.



Rearview camera (option)



### Safe and Easy Entry into and Exit from the Cab

A large handrail for easy opening/closing of the door and increased floor space permit the operator to get in and out of the cab easily.



### Easy Access to the Upper Structure

ISO compliant hand grip and lower step allow easy access to the upper structure. Shape of the right-hand corner cover has been optimised for better visibility from the cabin.



ISO-compliant hand grip and lower step

Hand grip  
Lower step

### New OPG Level 2 Head Guard

OPG Level 2 head guard is available as an option. The see-through grille has been redesigned for better protection and visibility.



### ISO Compliant Rearview Mirror

The new ISO compliant rearview mirrors reduce blind spots during operation. Together with the front mirrors, visibility is secured for safe operation.



Front/Side mirror



Rearview mirrors

### Safety Equipment



Anti-theft alarm system



Emergency stop switch



### Large High-Definition LCD Monitor

A new large high-definition full colour LCD monitor has been introduced with better visibility and a switch panel which is easy to operate. Added functionality such as ECO gauge showing parameter of energy saving, display of operation status and warning messages, provides accurate information which improves work efficiency and safety.

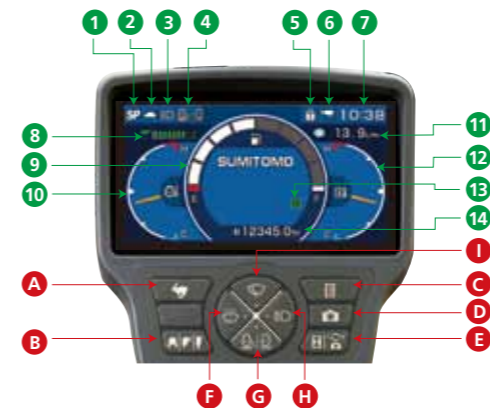

#### Indicators

- 1 Working modes
- 2 Travel speed
- 3 Work lights
- 4 Engine idle modes
- 5 Anti-theft
- 6 Attachment selection
- 7 Digital clock
- 8 ECO gauge
- 9 Fuel level gauge
- 10 Engine coolant temperature
- 11 Fuel consumption indicator
- 12 Hydraulic oil temperature
- 13 Radio mute
- 14 Hour meter

#### Switch Panel

- A Travel speed button
- B Aux. hydraulics settings
- C Computer menu
- D Camera on/off
- E Hour meter / Camera toggle button
- F Window washer control
- G Engine idle mode button
- H Worklights on/off
- I Window wiper control

### Super Comfortable Cab Mounts and Pressurised Cab

Fluid mounts that support the cab absorb shocks and vibrations effectively, improving ride comfort. The cab also features a pressurised design to prevent dust from entering inside, giving operators greater comfort.

#### Fluid mount

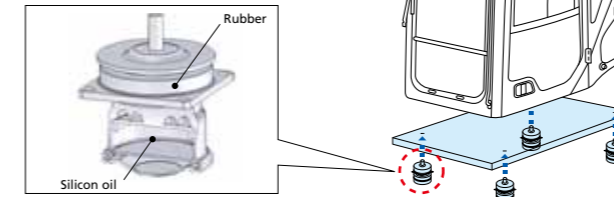

### Automatic Air Conditioner

An automatic air conditioner is included to keep the cab interior at the ideal temperature. The sealed, pressurised cab helps to increase air conditioner efficiency.



Operating panel

### Ample Legroom and Comfortable Seats

Legroom around the cab has been increased for comfortable operations. The operator seat features a head rest and arm rests, and comes with a wide range of seat adjustment functions with a comfortable suspension system.



Air suspension seat (option)

### Radio and Speaker with MP3 Jack

In addition to the AM/FM radio and dual speaker system with improved sound quality, auxiliary audio port is provided standard for devices such as MP3 players.



Operating panel

### Roof Window for Greater Freedom

A new pop-up roof window (made of polycarbonate) with sun shade has been installed for greater comfort.



### Under-cab Storage Space

Storage space has been included under the cab for various tools.



## Safety and Operator Comfort

The spacious cab on fluid mounts and reclining suspension seat help reduce operator fatigue and provide a relaxed environment.



### Comfortable Equipment



Cup holder

Magazine rack

# Specifications

## SH75X-6A / SH75XU-6A / SH80BS-6A Technical Data

Electronic-controlled engine of SPACE 5+ and SIH:S+ with New Hydraulic System Includes: three working modes (SP, H and A), and one-touch/automatic idling system.

### Engine

	SH75X-6A	SH75XU-6A	SH80BS-6A
Model	ISUZU AP-4LE2X		
Type	Water-cooled, 4-cycle diesel, 4-cylinder in line, high pressure common rail system (electric control), turbocharger with air cooled intercooler, DOC.		
Rated output	40.0 kW /2,000 min <sup>-1</sup>		
Maximum torque	193 N·m at 1,800 min <sup>-1</sup>		
Piston displacement	2.179 ltr		
Bore and stroke	85 mm x 96 mm		
Starting system	24 V electric motor starting		
Alternator	24 V, 50 A		
Fuel tank	120 ltr		
Air filter	Double element		

### Hydraulic pumps

Two variable displacement axial piston pumps provide power for boom/arm/bucket, swing, and travel. One gear pump for pilot controls.

	SH75X-6A	SH75XU-6A	SH80BS-6A
Maximum oil flow	2 x 74 ltr/min		
Pilot pump max. oil flow	18 ltr/min		

### Hydraulic motors

For travel: Two variable displacement axial piston motors.  
For swing: One fixed displacement axial piston motor.

### Relief valve settings

Boom/arm/bucket ..... 29.4 MPa (300 kgf/cm<sup>2</sup>)  
Swing circuit ..... 22.6 MPa (230 kgf/cm<sup>2</sup>)  
Travel circuit ..... 29.4 MPa (300 kgf/cm<sup>2</sup>)

### Control valve

**SH75X-6A**  
With boom holding valve  
One 4-spool valve for right track travel, bucket, boom and arm acceleration  
One 5-spool valve for left track travel, auxiliary, swing, boom acceleration and arm  
One 1-spool valve for blade

**SH75XU-6A**  
With boom holding valve  
One 5-spool valve for right track travel, bucket, boom, arm acceleration and offset  
One 5-spool valve for left track travel, auxiliary, swing, boom acceleration and arm  
One 1-spool valve for blade

**SH80BS-6A**  
With boom holding valve  
One 5-spool valve for right track travel, bucket, boom, arm acceleration and boom swing  
One 5-spool valve for left track travel, auxiliary, swing, boom acceleration and arm  
One 1-spool valve for blade

### Oil filtration

Return filter ..... 6 microns  
Pilot filter ..... 8 microns  
Suction filter ..... 105 microns

### Hydraulic cylinders

	Cylinder	Q'ty	Bore x Rod Diameter x Stroke
SH75X-6A	Boom	1	115 mm x 75 mm x 850 mm
	Arm	1	100 mm x 65 mm x 755 mm
	Bucket	1	85 mm x 55 mm x 665 mm
	Blade	1	110 mm x 70 mm x 180 mm

	Cylinder	Q'ty	Bore x Rod Diameter x Stroke
SH75XU-6A	Boom	1	115 mm x 75 mm x 850 mm
	Arm	1	95 mm x 60 mm x 685 mm
	Offset	1	100 mm x 55 mm x 315 mm
	Bucket	1	85 mm x 55 mm x 665 mm
	Blade	1	110 mm x 70 mm x 180 mm

	Cylinder	Q'ty	Bore x Rod Diameter x Stroke
SH80BS-6A	Boom	1	115 mm x 75 mm x 850 mm
	Arm	1	100 mm x 65 mm x 755 mm
	Boom Swing	1	95 mm x 55 mm x 675 mm
	Bucket	1	85 mm x 55 mm x 665 mm
	Blade	1	110 mm x 70 mm x 180 mm

Double-acting, bolt-up type cylinder tube-end; hardened steel bushings installed in cylinder tube and rods ends.

### Cab & controls

Roll-over protective structure (ROPS) cab, top guard OPG level1 (in cab structure). Cab mounted on four fluid mountings. Features include safety glass front, rear and side windows, adjustable upholstered suspension seat with headrest and armrest, pop-up skylight window, and intermittent wiper with washer. Front window slides upward for storage and the lower front window is removable. Built-in type full-colour monitor display. Membrane switch on monitor display.

### Swing

Planetary reduction powered by axial piston motor. The internal ring gear with grease cavity for pinion. Swing bearing is single-row shear type ball bearing. Dual stage relief valves for smooth swing deceleration and stops. Mechanical disc swing brake.

	SH75X-6A	SH75XU-6A	SH80BS-6A
Swing speed	0~10.4 min <sup>-1</sup>		
Tail swing radius	1,290 mm		1,680 mm
Swing torque	17.0 kN·m (1,734 kgf·m)		

### Undercarriage

X-style carbody is integrally welded for strength and durability. Grease cylinder track adjusters with shock absorbing springs. Undercarriage with lubricated rollers and idlers.

### Type of shoe: sealed link shoe

#### Upper rollers -

Heat treated, mounted on steel bushings with leaded tin bronze casting, sealed for lifetime lubrication.

#### Lower rollers -

Heat treated, mounted on steel bushings with leaded tin bronze casting, sealed for lifetime lubrication.

#### Track adjustment -

Idler axles adjusted with grease cylinder integral with each side frame; adjustment yoke mechanism fitted with heavy duty recoil spring.

### Number of rollers and shoes on each side

	SH75X-6A	SH75XU-6A	SH80BS-6A
Upper rollers	1		
Lower rollers	5		
Track shoes	39		

### Travel system

Two-speed independent hydrostatic system with compact axial motors for increased performance. Hydraulic motor powered output shaft coupled to a planetary reduction unit and track sprocket. All hydraulic components mounted within the width of side frame. Travel speed can be selected by switch panel. Hydraulically released disc parking brake is built into each motor.

	SH75X-6A	SH75XU-6A	SH80BS-6A
Travel speed	High	5.1 km/h	
	Low	3.2 km/h	
Drawbar pull	59.5 kN (6,067 kgf)		

### Auxiliary hydraulic system

	SH75X-6A/SH80BS-6A			SH75XU-6A
Auxiliary piping type (option)	For Breaker	For Double (breaker & crusher) acting	For D/A + Second option line	For Breaker
Arm type	STD	Reinforced	Reinforced	STD
Bucket linkage type	HD	HD	HD	HD
Auxiliary hydraulic pump flow	74 ltr/min	148 ltr/min	148+35 ltr/min	74 ltr/min

### Lubricant & coolant capacity

	SH75X-6A	SH75XU-6A	SH80BS-6A
Hydraulic system	96.3 ltr		
Hydraulic oil tank	51 ltr		
Fuel tank	120 ltr		
Cooling system	12.2 ltr		
Final drive case (per side)	1.1 ltr		
Engine crank case	11.5 ltr		

### Bucket

Model	SH75X-6A/SH75XU-6A/SH80BS-6A				
Bucket capacity (ISO/SAE/PCSA heaped)	0.11 m <sup>3</sup>	0.17 m <sup>3</sup>	0.22 m <sup>3</sup>	0.28 m <sup>3</sup>	0.34 m <sup>3</sup>
Bucket capacity (CECE heaped)	0.10 m <sup>3</sup>	0.15 m <sup>3</sup>	0.19 m <sup>3</sup>	0.24 m <sup>3</sup>	0.30 m <sup>3</sup>
Bucket type	STD	STD	STD	STD	STD
Number of teeth	3	3	3	4	4
Width (mm)	With side cutter	—	—	673	934
	Without side cutter	370	490	600	860
Weight (kg)	137	162	184	209	227
Combination (SH75X-6A/80BS-6A)	1.69 m arm	⊙	⊙	⊙	●
	2.19 m arm	⊙	⊙	●	△
Combination (SH75XU-6A)	1.75 m arm	⊙	⊙	⊙	●
	2.10 m arm	⊙	⊙	●	×

⊙ Suitable for materials with density up to 2,000 kg/m<sup>3</sup> or less

● Standard bucket (suitable for materials with density up to 1,800 kg/m<sup>3</sup> or less)

○ Suitable for materials with density up to 1,600 kg/m<sup>3</sup> or less

△ Suitable for materials with density up to 1,200 kg/m<sup>3</sup> or less

× Not available

### Weight & Ground Pressure

	Shoe type	Shoe width	Overall width	Operating weight	Ground pressure
SH75X-6A	Triple grouser shoe	450 mm	2,320 mm	7,880 kg	35 kPa
		600 mm	2,470 mm	8,010 kg	31 kPa
SH75XU-6A	Triple grouser shoe	450 mm	2,320 mm	8,260 kg	37 kPa
		600 mm	2,470 mm	8,390 kg	32 kPa
SH80BS-6A	Triple grouser shoe	450 mm	2,320 mm	8,570 kg	38 kPa
		600 mm	2,470 mm	8,700 kg	34 kPa

### Digging Force

Model	SH75X-6A/SH80BS-6A		SH75XU-6A	
Arm length	1.69 m	2.19 m	1.75 m	2.10 m
Bucket digging force	ISO 6015	56.9 kN	56.9 kN	56.9 kN
	SAE: PCSA	49.9 kN	49.9 kN	49.9 kN
Arm digging force	ISO 6015	39.5 kN	33.8 kN	39.4 kN
	SAE: PCSA	37.9 kN	32.7 kN	37.8 kN





## Lifting Capacity

Notes: 1. Ratings are based on ISO 10567

- Lifting capacity does not exceed 75% of tipping load with the machine on firm, level ground or 87% full hydraulic capacity.
- The load point is a hook (not standard equipment) located on the back of the bucket.
- \*Indicates load limited by hydraulic capacity.
- 0 m = Ground.

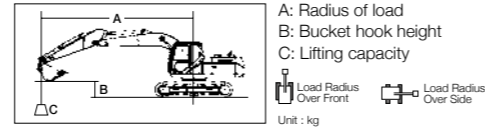

SH80BS-6A		SHOE : 450 (mm)G BUCKET : SAE/PCSA 0.22 (m³)		ARM LENGTH : 2.19 (m) MAXIMUM REACH : 7.56 (m)		BOOM : 3.50 (m) BLADE : Down		Radius of Load								
Bucket Hook Height	Max. Radius				6 m		4.5 m		3 m		1.5 m		Min. Radius			
	(kg)	(m)	(kg)	(m)	(kg)	(m)	(kg)	(m)	(kg)	(m)	(kg)	(m)	(kg)	(m)	(kg)	(m)
6 m	1 090*	5.17	1 090*	5.17									1 170*	4.78	1 170*	4.78
4.5 m	950*	6.51	950*	6.51	1 380*	1 200							1 410*	4.76	1 410*	4.76
3 m	930*	7.14	850	7.14	1 650*	1 170	1 700*	1 700*					1 700*	4.11	1 700*	4.11
1.5 m	990*	7.3	800	7.3	1 900*	1 120	2 570*	1 760	3 970*	3 330			1 680*	2.61	1 680*	2.61
0 m	1 130*	7.06	830	7.06	2 130*	1 070	3 120*	1 650	4 010*	3 030			1 580*	1.91	1 580*	1.91
-1.5 m	1 460*	6.4	960	6.4	2 090*	1 050	3 170*	1 610	5 110*	3 010	2 720*	2 720*	2 160*	0.48	2 160*	0.48
-3 m	1 990*	5.18	1 320	5.18			2 670*	1 660	4 670*	3 090	4 820*	4 820*	3 790*	0.98	3 790*	0.98

SH80BS-6A		SHOE : 450 (mm)G BUCKET : SAE/PCSA 0.22 (m³)		ARM LENGTH : 2.19 (m) MAXIMUM REACH : 7.56 (m)		BOOM : 3.50 (m) BLADE : Up		Radius of Load								
Bucket Hook Height	Max. Radius				6 m		4.5 m		3 m		1.5 m		Min. Radius			
	(kg)	(m)	(kg)	(m)	(kg)	(m)	(kg)	(m)	(kg)	(m)	(kg)	(m)	(kg)	(m)	(kg)	(m)
6 m	1 090*	5.17	1 090*	5.17									1 170*	4.78	1 170*	4.78
4.5 m	950*	6.51	950*	6.51	1 260	1 150							1 410*	4.76	1 410*	4.76
3 m	900	7.14	820	7.14	1 230	1 120	1 700*	1 700*					1 700*	4.11	1 700*	4.11
1.5 m	840	7.3	760	7.3	1 170	1 070	1 860	1 690	3 580	3 180			1 680*	2.61	1 680*	2.61
0 m	870	7.06	790	7.06	1 120	1 020	1 750	1 580	3 270	2 890			1 580*	1.91	1 580*	1.91
-1.5 m	1 010	6.4	910	6.4	1 110	1 010	1 700	1 540	3 250	2 870	2 720*	2 720*	2 160*	0.48	2 160*	0.48
-3 m	1 390	5.18	1 270	5.18			1 760	1 590	3 330	2 950	4 820*	4 820*	3 790*	0.98	3 790*	0.98

SH80BS-6A		SHOE : 450 (mm)G BUCKET : SAE/PCSA 0.28 (m³)		ARM LENGTH : 1.69 (m) MAXIMUM REACH : 7.09 (m)		BOOM : 3.50 (m) BLADE : Down		Radius of Load								
Bucket Hook Height	Max. Radius				6 m		4.5 m		3 m		1.5 m		Min. Radius			
	(kg)	(m)	(kg)	(m)	(kg)	(m)	(kg)	(m)	(kg)	(m)	(kg)	(m)	(kg)	(m)	(kg)	(m)
4.5 m	1 100*	5.95	1 100*	5.95			1 680*	1 680*					1 670*	4.26	1 670*	4.26
3 m	1 080*	6.65	950	6.65	1 750*	1 140	2 060*	1 840					2 250*	3.28	2 250*	3.28
1.5 m	1 160*	6.83	890	6.83	2 020*	1 100	2 800*	1 730	4 730*	3 200			2 230*	2.72	2 230*	2.72
0 m	1 340*	6.57	920	6.57	2 150*	1 060	3 190*	1 640	3 770*	3 000			1 820*	2.09	1 820*	2.09
-1.5 m	1 820*	5.84	1 100	5.84			3 110*	1 620	5 430*	3 040	3 300*	3 300*	2 760*	0.98	2 760*	0.98
-3 m	2 110*	4.47	1 670	4.47					3 970*	3 130			5 580*	1.63	5 580*	1.63

SH80BS-6A		SHOE : 450 (mm)G BUCKET : SAE/PCSA 0.28 (m³)		ARM LENGTH : 1.69 (m) MAXIMUM REACH : 7.09 (m)		BOOM : 3.50 (m) BLADE : Up		Radius of Load								
Bucket Hook Height	Max. Radius				6 m		4.5 m		3 m		1.5 m		Min. Radius			
	(kg)	(m)	(kg)	(m)	(kg)	(m)	(kg)	(m)	(kg)	(m)	(kg)	(m)	(kg)	(m)	(kg)	(m)
4.5 m	1 100*	5.95	1 100*	5.95			1 680*	1 680*					1 670*	4.26	1 670*	4.26
3 m	1 000	6.65	910	6.65	1 200	1 100	1 930	1 770					2 250*	3.28	2 250*	3.28
1.5 m	930	6.83	850	6.83	1 150	1 050	1 820	1 660	3 450	3 050			2 230*	2.72	2 230*	2.72
0 m	970	6.57	880	6.57	1 120	1 020	1 730	1 560	3 230	2 860			1 820*	2.09	1 820*	2.09
-1.5 m	1 160	5.84	1 060	5.84			1 710	1 550	3 280	2 900	3 300*	3 300*	2 760*	0.98	2 760*	0.98
-3 m	1 770	4.47	1 600	4.47					3 360	2 990			5 580*	1.63	5 580*	1.63

## Principle Specifications

	SH75X-6A	SH75XU-6A	SH80BS-6A	
	STD Specifications			
Base	Std. operating weight	7,880 kg	8,260 kg	8,570 kg
	Boom length	3.75 m	3.89 m	3.50 m
	Arm length	1.69 m	1.75 m	1.69 m
	Bucket capacity (ISO heaped)		0.28 m³	
Engine	Shoe width		450 mm	
	Counterweight	970 kg	970 kg	1,100 kg
Hydraulic System	Make & model	ISUZU AP-4LE2X		
	Rated output	40.0 kW/2,000 min <sup>-1</sup>		
	Piston displacement	2.179 ltr		
Performance	Main pump	2 variable displacement axial piston pumps with regulating system		
	Max oil flow	2 × 74 ltr/min		
	Max pressure	29.4 MPa		
	Travel motor	Variable displacement axial piston motor		
Others	Parking brake	Mechanical disc brake		
	Swing motor	Fixed displacement axial piston motor		
Performance	Travel speed	5.1/3.2 km/h		
	Drawbar pull	59.5 kN		
	Gradeability	70% <35° >		
	Ground pressure	35 kPa	37 kPa	38 kPa
	Max swing speed	10.4 min <sup>-1</sup>		
	Swing torque	17.0 kN·m (1,734 kgf·m)		
	Bucket digging force (ISO 6015)	56.9 kN		
	Arm digging force (ISO 6015)	39.5 kN	39.4 kN	39.5 kN
	Fuel tank	120 ltr		
	Hydraulic oil tank	51 ltr		

## Standard Equipment

### [Hydraulic system]

- SIH-S+ hydraulic system
- Operation mode (SP, H and A mode)
- Automatic 2-speed travel
- Arm reactivation circuit
- Automatic swing parking system
- High-performance return filter

### [Safety equipment]

- Rearview mirror (left/right)
- Emergency escape tool
- Retracting seat belt
- Gate lock lever
- Travel alarm (with on and off switch)
- Anti-theft alarm system
- Engine room firewall
- Fan guard
- Engine emergency stop switch
- Engine neutral start

### [Cab/interior equipment]

- Roll-over protective structure (ROPS) cab
- Top guard OPG level 1 (in cab structure)
- 4-point fluid mounts
- Built-in type full-colour monitor display
- Open air introducing pressurised full-automatic air conditioner
- Defroster
- KAB seat
- Seat suspension
- Windscreen wiper (with intermittent operation function)
- Cup holder
- AM/FM radio (with muting function and AUX port)
- Radio mute/Windscreen wiper one-touch control on joystick
- Clock
- Magazine rack
- Accessory case
- Floor mat
- Armrest & headrest
- Cab light (Auto-OFF function)
- 12V power (DC-DC converter)
- Coat hook

### [Others]

- Auto/one-touch idling
- Auto idle shutdown system
- EMS
- Long-life hydraulic oil
- Two lights (main unit and right of boom)
- Fuel filter (with water separator)
- Fuel prefilter (with water separator)
- Double-element air cleaner
- Grease-enclosed track link
- Large tool box
- A set of tools

## Accessories (option)

### ■ Cab-top lights



### ■ Air suspension (KAB seat)



### ■ Front guard (OPG level 1 or 2)



### ■ Head guard (OPG level 2)



### ■ Refuel pump

- Hose burst check valve (HBCV) for boom/arm cylinders
- Rearview camera

## SH75X-6A

### Working Range

SH75X-6A		
Arm length	1.69 m (STD)	2.19 m (LONG)
Boom length	3.75 m	
A Max digging radius	6,410 mm	6,890 mm
B Max digging depth	4,130 mm	4,630 mm
C Max digging height	7,370 mm	7,770 mm
D Max dumping height	5,280 mm	5,670 mm
E Max vertical wall cut depth	3,640 mm	4,200 mm
F Min front swing radius	1,630 mm	1,970 mm
G Tail swing radius	1,290 mm	
H Max lift above ground	440 mm	
I Min drop below ground	280 mm	

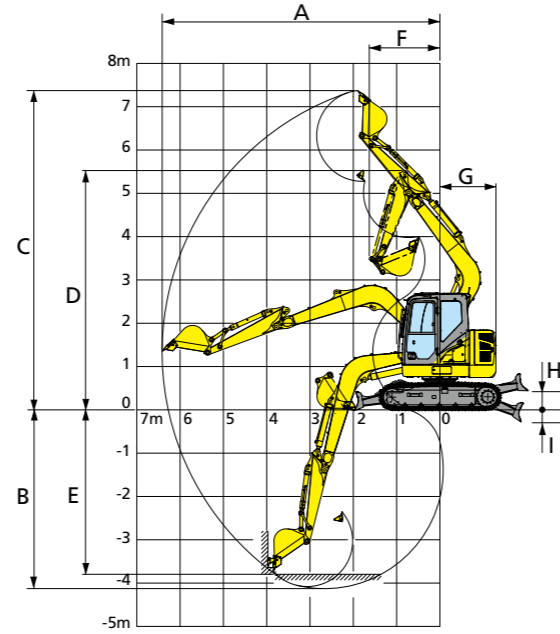

## SH75XU-6A

### Working Range

SH75XU-6		
Arm length	1.75 m arm (STD)	2.10 m arm (LONG)
Boom length	3.89 m	
A Max digging radius	6,500 mm	6,790 mm
B Max digging depth	4,250 mm	4,600 mm
C Max digging height	7,380 mm	7,590 mm
D Max dumping height	5,310 mm	5,520 mm
E Max vertical wall cut depth	3,330 mm	3,680 mm
F Min front swing radius	2,130 mm	2,360 mm
G Tail swing radius	1,290 mm	
H Max lift above ground	440 mm	
I Min drop below ground	280 mm	

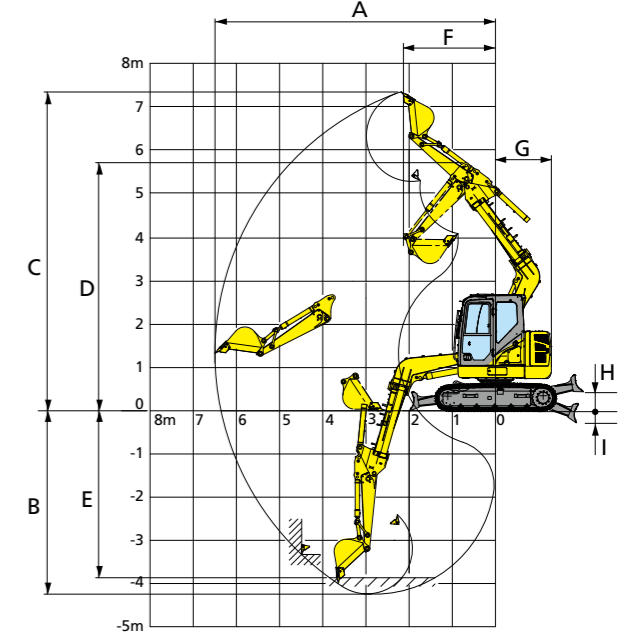

### Dimensions

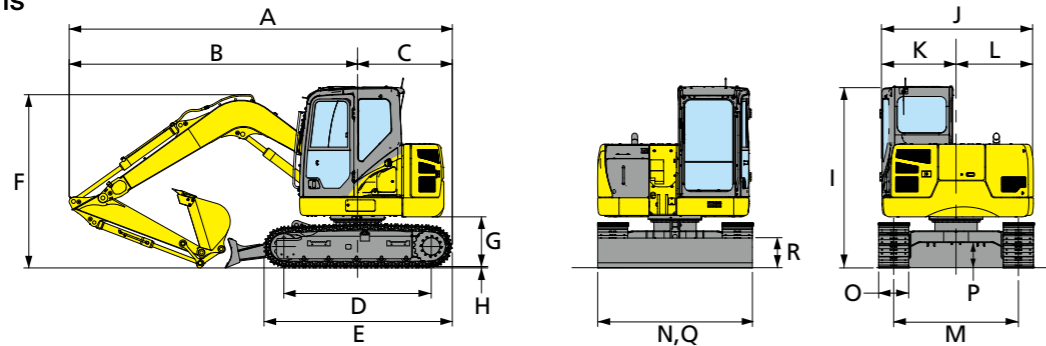

Model	SH75X-6A	
Arm length	1.69 m	2.19 m
A Overall length	5,755 mm	6,340 mm
B Length from centre of machine (to arm top)	4,330 mm	4,350 mm
C Length from centre of machine (to track end)	1,425 mm	
D Centre to centre of wheels	2,210 mm	
E Overall track length	2,845 mm	
F Overall height (to top of boom)	2,600 mm	2,860 mm
G Clearance height under upper structure	750 mm	
H Shoe lug height	20 mm	
I Overall height (to top of cab)	2,850 mm	
J Upper structure overall width	2,270 mm	
K Width from centre of machine (left side)	1,110 mm	
L Width from centre of machine (right side)	1,160 mm	
M Track gauge	1,870 mm	
N Overall width	2,320 mm	
O Std. shoe width	450 mm	
P Minimum ground clearance	360 mm	
Q Width of blade	2,320 mm	
R Height of blade	450 mm	

### Dimensions

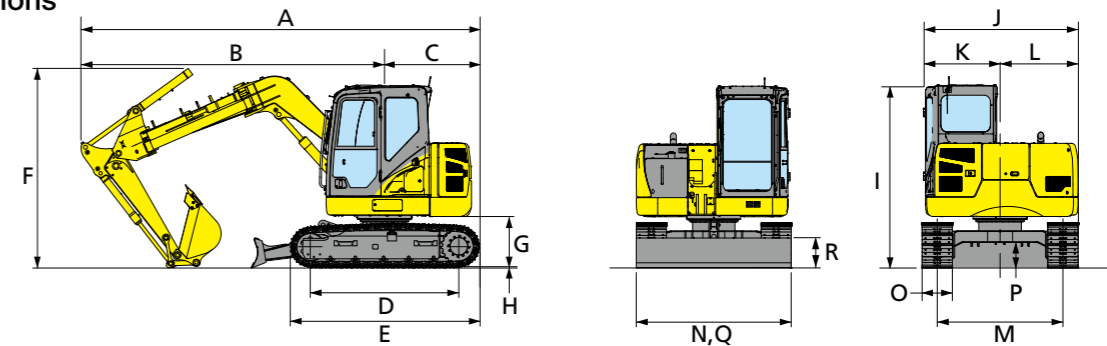

Model	SH75XU-6A	
Arm length	1.75 m	2.10 m
A Overall length	5,945 mm	5,875 mm
B Length from centre of machine (to arm top)	4,520 mm	4,450 mm
C Length from centre of machine (to track end)	1,425 mm	
D Centre to centre of wheels	2,210 mm	
E Overall track length	2,845 mm	
F Overall height (to top of boom)	2,970 mm	3,160 mm
G Clearance height under upper structure	750 mm	
H Shoe lug height	20 mm	
I Overall height (to top of cab)	2,850 mm	
J Upper structure overall width	2,270 mm	
K Width from centre of machine (left side)	1,110 mm	
L Width from centre of machine (right side)	1,160 mm	
M Track gauge	1,870 mm	
N Overall width	2,320 mm	
O Std. shoe width	450 mm	
P Minimum ground clearance	360 mm	
Q Width of blade	2,320 mm	
R Height of blade	450 mm	

**Working Range**

SH80BS-6A		
Arm length	1.69 m arm (STD)	2.19 m arm (LONG)
Boom length	3.50 m	
A Max digging radius	7,090 mm	7,560 mm
B Max digging depth	4,180 mm	4,670 mm
C Max digging height	6,570 mm	6,890 mm
D Max dumping height	4,530 mm	4,850 mm
E Max vertical wall cut depth	3,350 mm	3,920 mm
F Min front swing radius	2,790 mm	3,030 mm
G Tail swing radius	1,680 mm	
H Max lift above ground	440 mm	
I Min drop below ground	280 mm	

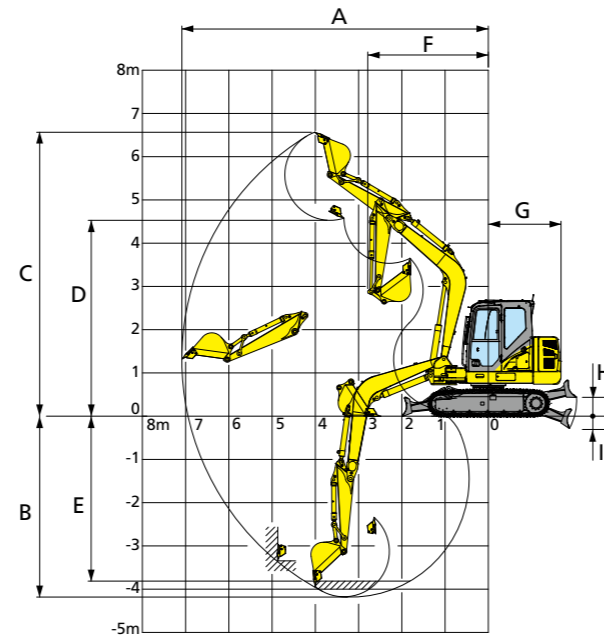

**Dimensions**

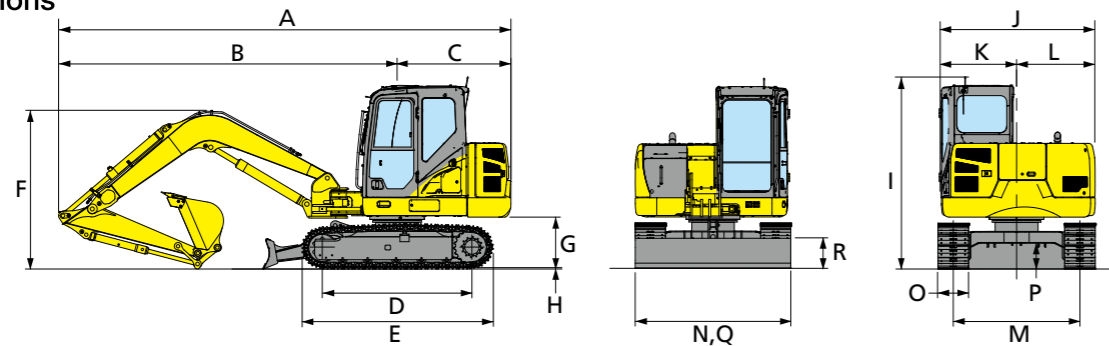

Model	SH80BS-6A	
Arm length	1.69 m	2.19 m
A Overall length	6,680 mm	6,730 mm
B Length from centre of machine (to arm top)	5,000 mm	5,050 mm
C Upper structure rear end radius	1,680 mm	
D Centre to centre of wheels	2,210 mm	
E Overall track length	2,845 mm	
F Overall height (to top of boom)	2,340 mm	2,740 mm
G Clearance height under upper structure	750 mm	
H Shoe lug height	20 mm	
I Overall height (to top of cab)	2,850 mm	
J Upper structure overall width	2,270 mm	
K Width from centre of machine (left side)	1,110 mm	
L Width from centre of machine (right side)	1,160 mm	
M Track gauge	1,870 mm	
N Overall width	2,320 mm	
O Std. shoe width	450 mm	
P Minimum ground clearance	360 mm	
Q Width of blade	2,320 mm	
R Height of blade	450 mm	