

# SUMITOMO

## SH130-7 Hydraulic Excavator

 **SUMITOMO CONSTRUCTION  
MACHINERY CO., LTD.**

731-1 Naganumahara-cho, Inage-ku, Chiba, 263-0001 Japan  
For further information please contact: Phone : +81-43-420-1829 Facsimile : +81-43-420-1907

We are constantly improving our products and therefore reserve the right to change designs and specifications without notice.  
Illustrations may include optional equipment and accessories and may not include all standard equipment.



# SUMITOMO

## EXCAVATORS

### SH130-7

- Engine Rated Power (Net): 76.4 kW
- Operating Weight:
  - SH130-7 ..... 13,200 kg~13,900 kg
- Bucket Capacity (ISO Heaped): 0.5 m<sup>3</sup>~0.65 m<sup>3</sup>

HYDRAULIC EXCAVATOR FOR REAL PERFORMANCE

### LEGEST



**EU Stage V**



# Advances Abound. Innovation Infinite.

Setting a new bar for worksite proficiencies.  
**The All-new LEGEST.**

The new LEGEST series from Sumitomo has been developed to exceed its own capabilities in every regard, with performance benchmarks that will stand the test of time and innovation to tackle any job. Created for more seamless operations in an extensive range of worksite surroundings, both businesses and operators will come to treasure the performance the LEGEST is capable of providing. Unleash the potential on your worksite with capabilities never before seen.

**LEGEST**

## Advanced Energy Efficiency and Eco-friendly Operation 04-07

- Clean and Fuel-efficient Engine "SPACE 5 α"
- Innovative Hydraulic System "SIH:S α"
- SUMITOMO Technology for Fuel Efficiency

## Unparalleled Performance 08-09

## Advanced Operator Comfort 10-11

- New Monitor
- New Air Suspension Seat

## Sophisticated Safety Features 12-13

- Rear and Right Side Camera

## Superior Ease-of-maintenance and Durability 14-16

- Ground Level Access
- EMS

## Specifications 17-23



## Advanced Energy Efficiency and Eco-friendly Operation

The combination of the advanced clean engine "SPACE 5 α" and SUMITOMO's proprietary hydraulic system "SIH:S α" achieves much higher operating efficiency and superior fuel economy. These features also mean the excavator is even easier on the environment and worksites.

## Faster Operations and Excellent Fuel Economy! H Mode for Equivalent or Better Productivity than Previous SP Mode!

Clean engine **SPACE 5 α** × Innovative hydraulic system **SIH:S α** = **7%\* less fuel consumption**

\* Comparison of fuel consumption with same workload (SH130-7 H mode compared against SH130-6 SP mode)  
The level of reduction may be less than shown above depending on actual job type.

### Meets EU Stage V standards

The clean engine "SPACE 5 α" achieves significant reductions in exhaust gas emissions, meeting European Stage V non-road emission standards (EU Stage V), deemed the toughest emissions standards in the world. The SH130-7 series excavator has been designed to be even more environmentally friendly.

**NOx: 91% reduction**  
**PM: 96% reduction**  
(compared to SH130-6)

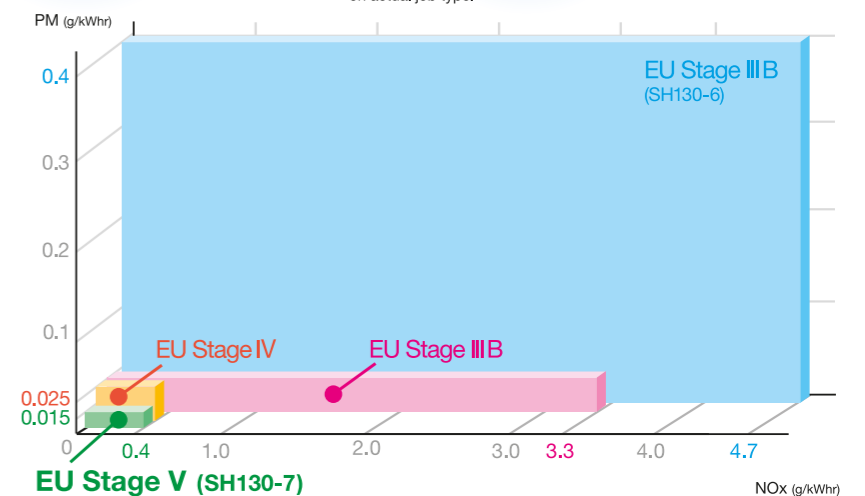

### Clean and Fuel-efficient Engine "SPACE 5 α"

The SH130-7 is powered by a new engine designed for significantly improved combustion efficiency and much lower fuel consumption. In addition to a common rail fuel injection system designed for optimum fuel injection, a cooled EGR and VG turbocharger help to achieve cleaner exhaust gas emissions as well as superior power and response.

### Exhaust After Treatment System (ATS)

An advanced exhaust after treatment system has been used, featuring a combination of a ceramic filter and SCR. The pre-stage ceramic filter removes PM through collection and combustion, while the post-stage SCR injects AdBlue® (urea water) into the exhaust gas, cleaning the NOx into harmless nitrogen and water through chemical reaction. Post treatment of NOx allows for high-efficiency combustion at the engine, achieving superior clean running as well as powerful and low fuel consumption operation.

AdBlue® is a registered trademark of the German Association of the Automotive Industry.

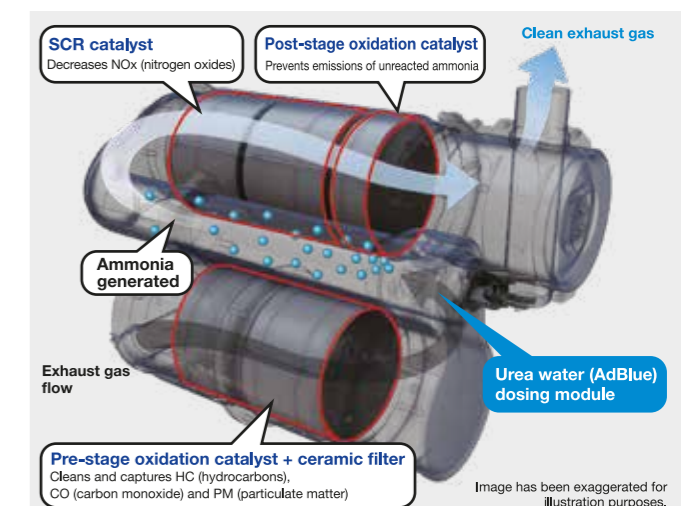

### SCR System Design

The SCR system comprises an oxidation catalyst, SCR catalyst and urea water dosing module. The urea water is injected into the exhaust gas, where the NOx is reduced by the SCR catalyst and ammonia generated from the urea water and broken down into harmless nitrogen and water, resulting in clean exhaust gases.

SCR: Selective Catalytic Reduction



## Advanced Energy Efficiency and Eco-friendly Operation

### Innovative Hydraulic System "SIH:S α"

An innovative hydraulic system has been used to reduce fuel consumption, while a fully electronically controlled hydraulic pump ensures precision flow control. Further enhancements have also been made to SUMITOMO's proprietary Spool Stroke Control for optimum hydraulic control to suit job conditions, thus achieving even more efficient operations and significantly lower fuel consumption.

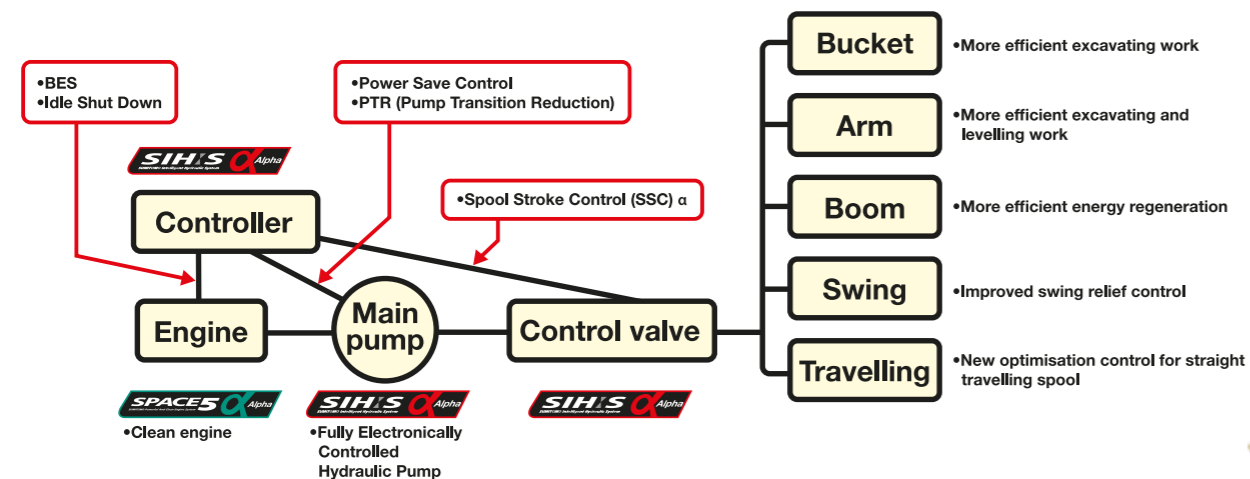

### Three Working Modes for Economic Operation or Work Efficiency



Three working modes are available: SP (Super Power) for faster operations, H (Heavy) for heavy duty applications, and A (Auto) for fuel efficiency across a wide range of operations. Six levels are shown for A mode, making it easier to select the right mode for any jobsite.



#### Integrated Throttle Mode Selector

The throttle mode can be selected by simply turning the knob, so anyone can easily choose the optimum working mode.

### SUMITOMO Technology for Fuel Efficiency

#### •Spool Stroke Control (SSC) α SUMITOMO UNIQUE DESIGN

Automatically adjusts hydraulic pressure to save fuel. Better precision for identifying operating conditions and greater range of control help to reduce fuel consumption and increase operating efficiency even further.

#### •Fully Electronically Controlled Hydraulic Pump

Designed with ultra-sensitive hydraulic pressure sensing technology for precision flow rate control to suit any type of job. These help to achieve speed, enhance operations and reduce fuel consumption.

#### •Power Save Control SUMITOMO UNIQUE DESIGN

Reduces the flow rate of the main pump when the machine is not in operation, which cuts down unnecessary fuel consumption.

#### •BES (Boom-down Energy Save) SUMITOMO UNIQUE DESIGN

Increases fuel efficiency during boom-down operation.

#### •PTR (Pump Transition Reduction) SUMITOMO UNIQUE DESIGN

Decreases main pump loads to reduce fuel consumption.

#### •Idle Shut Down & Auto Idle

Detects when the machine is not in operation, and automatically stops the engine from idling. Also equipped with Auto Idle, which automatically switches the engine to idle when the operation levers are in neutral position.



## Unparalleled Performance

The Innovative Hydraulic System “SIH:S α” provides a stunning new level of performance on job sites. A fully electronically controlled hydraulic pump enhances engine and pump control, and when combined with SUMITOMO’s proprietary Spool Stroke Control (SSC) α, ensures precision control across the entire operating range. The excavator responds exactly as the operator is expecting, with predictable speed, digging power and movement streamlining work on any job site.

### Even faster operations

Advances and optimisations made to the hydraulic control system and the use of large capacity valves to reduce pressure loss help to reduce cycle time in all modes—boosting efficiency for site operations.

**SP mode: 3% faster cycle time**

**H mode: 4% faster cycle time**

**A mode: 5% faster cycle time**

(compared with SH130-6)

### Work Efficiency Drastically Increased

Spool Stroke Control (SSC) α provides precision optimal flow rate control to suit operating conditions. Speed, power, operations, and control are exactly as the operator expects, meaning work efficiency is increased dramatically. It now also covers a greater range, with more precise identification of operating type. These all help to achieve an even higher level of energy efficiency and smooth operations.

### Faster Cycle Time and Greater Productivity

Faster operation reduces cycle time, while smooth control of the hydraulics also achieves operability for precision works.







## Advanced Operator Comfort

A comfortable cabin has been designed to reduce operator fatigue, with the aim of relieving stress during work and ensuring greater relaxation during downtime. With features such as a spacious cabin interior, new high-definition monitor with smartphone-like usability, new air suspension seat, and unbelievably quiet operation, the cabin is both comfortable and intuitive to ensure a greater level of safety.

### New Monitor—Even More Intuitive and User-friendly

A wide range of excavator operating and maintenance information, warnings and other data are displayed as text messages. Providing a way to view accurate and easy-to-understand information helps to boost operating efficiency and safety.



### Illustrations of new monitor displays



### Indicators

- 1 Working modes
- 2 Icons
- 3 Warning messages
- 4 Engine coolant temperature
- 5 Fuel level
- 6 Urea water level
- 7 ATS warning
- 8 Camera view (rear camera)
- 9 Camera view (right side camera)

### Switch Panel

- A Travel speed button
- B ATS purge
- C Aux. hydraulic settings
- D Window wiper
- E Window washer
- F Work lights
- G Auto idle/Idle stop
- H Display modes
- I Hour meter toggle (trip/total)

### Spacious, Class-leading Cabin

Just like previous models, the cabin has been designed with features that are top of its class, all of which help to ensure a comfortable and stress-free space for the operator. Superior sound insulation throughout the cabin translates to top-class levels of silence within.

### Console-linked Arm Rest

The arm rest is linked with movement of the tilting console. The distance between the arm rest and operations levers remains the same, regardless of the angle of the console, leading to a greater level of comfort and control.



### New Air Suspension Seat

The operator's seat features air suspension as standard for outstanding ride comfort. A new high-performance reclining seat with higher seatback has been used to ensure premium comfort. A multitude of seat adjustments and ample seat cushion width all help to significantly lower operator fatigue. The high water-repellent seat material is also easier to keep clean.



Seat air suspension

### Premium Comfort with Seat Heater (OPTION)

A seat heater function is now available as an optional extra for even greater comfort in cold seasons or working early mornings. A convenient seat tilting function has also been added that allows the seat cushion to be tilted forward or back to suit the operator's body type or particular job—now anyone can achieve the optimum seating posture for more comfortable control.



Seat heater switch

### Automatic Air-conditioner

Fully automatic climate control maintains a comfortable temperature within the cabin. The optimal ducting layout and airtight cabin also help to boost air-conditioning efficiency.



### Equipment for Comfort and Safety



Rear luggage space    Hot & cool box    Magazine rack



Anti-theft system    Emergency stop switch





## Sophisticated Safety Features

The cabin provides excellent driving visibility, and features a high-strength design to better protect the operator. Every aspect has been designed for day-to-day safety, including excellent access in and out of the cabin, and steps and handrails to make inspections and maintenance easier. The use of rear and right side cameras also helps to ensure operations remain safe.

### Safe ROPS-compliant Cabin

A high-strength cabin design means operators are even better protected.

ROPS: Roll-Over Protective Structure

Moulded steel pipe

Square pipe

Thick plate

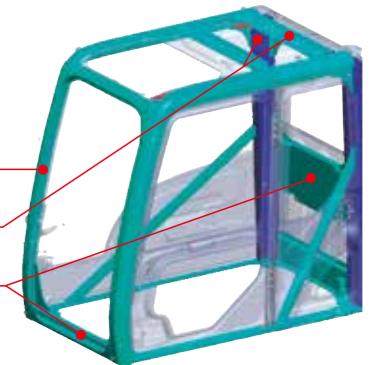

### Wide View for Excellent Site Safety

In addition to the front of the excavator, the cabin design gives the operator a wide, unrestricted view to check upper and lower areas. Direct visibility for the operator means work can be performed safer.



### Superb Access

The wide door opening and large handrails provide excellent access up to and down from the cabin. The spacious footwell also makes it easier to get in and out.



Large handrail and spacious footwell

### Rear and Right Side Cameras

Two cameras are installed as standard—rear view and on the right side—so the operator can check for safety behind the excavator. Optimally positioned mirrors and the use of cameras ensure that mirror visibility meets ISO standards, thus making it easier for the operator to check for safety in any desired direction.



Monitor videos

### Better Access Around Body

Steps and handrails are in the optimal positions for easier access around the body during inspections and maintenance. Non-slip plates also ensure safety when it is raining.



Handrails



Non-slip plates



Rear camera



Right side camera

### LED Cabin Top Light (OPTION)

A long-life LED cabin top light is now available as an optional extra. Super bright and with a high-visibility colour, the light enhances safety during night-time operations.



LED cabin top light





## Superior Ease-of-maintenance and Durability

Easy maintenance and durability are the key to excavators that are called upon for ongoing work at job sites. With enhanced durability at every corner and proprietary EMS, outstanding reliability is standard with SUMITOMO excavators—they are designed to be easy to operate and maintain for customers, including features like ground level access and refilling AdBlue®.

### Ground Level Access for Easy Inspections and Maintenance

Components requiring inspection are all in a central location, meaning inspections and refilling can be performed without having to climb up onto the excavator.

#### •Increased Cooling Performance

The use of a larger radiator and oil cooler help to increase cooling performance and reliability. It is also easier to clean the dust-proof net.

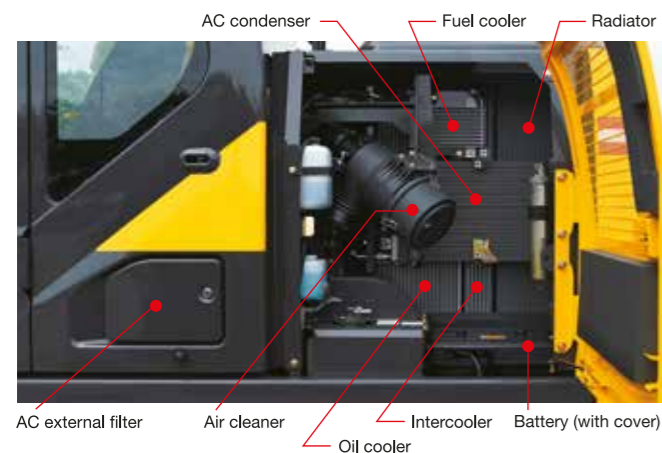

#### •Designed for Easy Filter Replacement

The pre-fuel filter is designed to reduce issues due to a blocked fuel filter, and the easily accessible location of the fuel and oil filters ensure smooth inspection and replacement work.

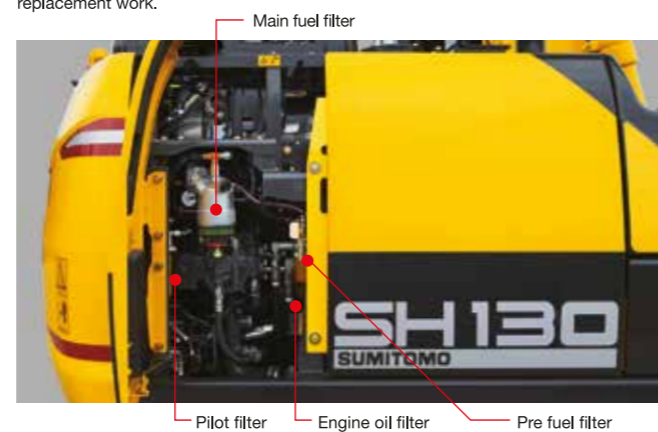

### Battery Cutoff Switch

A battery switch is mounted inside the inspection cover, ensuring safe operations during maintenance procedures.



### Other Maintenance Features



Central fuse box located behind seat



Easy-access AC filter



Washable cab floor and floor mats

### Dust-proof Net for Enhanced Ground Level Access

A dust-proof net mounted on the front of cooling package reduces the amount of dust adhesion, leading to a higher level of reliability. Ground level access means the dust-proof net can be quickly removed for easy cleaning.

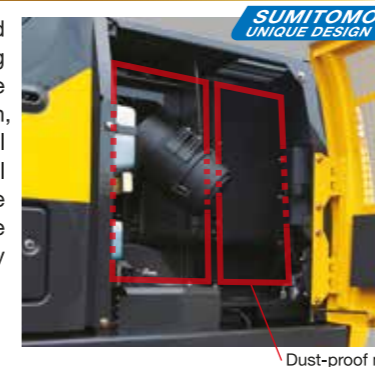

Dust-proof net

### High-Performance Return Filter

A long hydraulic oil change interval of 5,000 hours, and the use of a high-performance return filter ensures superior ease-of-maintenance.

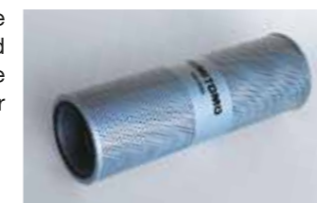

Hydraulic oil change: **5,000** hours  
Filter life: **2,000** hours

\* The oil and filter change intervals vary depending on operating conditions.

### Easy-to-fill Urea Tank

The urea tank has been positioned near the front right for easy refilling, to suit the way the excavator is used. In addition to easily refilling water by climbing up on the side frame, water can also be refilled by placing the AdBlue® container in front of the tank.



Urea Tank Capacity: **75 L**  
Refilling frequency: **Once per 9** refuellings

A large capacity tank has been used for longer refilling intervals and lower the amount of associated work. The tank needs to be refilled around once every nine times the fuel tank is filled (may vary depending on usage conditions).

### Precautions with machines installed with the SCR System

To ensure that the machine can be used safely and smoothly, use AdBlue® aqueous solution (or a urea aqueous solution that complies with ISO standards). Using a non-standard aqueous solution or diluting the solution before use may cause mechanical problems. Malfunctions arising from the use of non-standard aqueous solutions are not covered by SUMITOMO's warranty service.

- The remaining AdBlue® level can be checked during work on the monitor display in the cab. A warning is displayed on the monitor when the remaining level becomes low or there is an issue with quality.
- The engine power output will be limited if the remaining AdBlue® level falls below the minimum level or there is an issue with quality, so be sure to plan refills in advance.

#### Precautions when handling AdBlue®

- The SCR System is designed exclusively for the machine, and must not be used for any other purpose.
- Rinse with water any solution that comes in contact with skin.
- When storing the solution, always use sealed containers and store at room temperature in a well-ventilated location out of direct sunlight. When carrying the solution, always use the container that the solution was purchased in, or other specified container.
- The SCR System includes a heater function, however sufficient care must be taken to prevent freezing when the solution is stored in cold regions (freezing temperature: -11°C).



Example monitor warning display

Read the instruction manual for more details.



# Advances Abound. Innovation Infinite.



SUMITOMO  
UNIQUE DESIGN

## EMS for Enhanced Maintenance of Joints

SUMITOMO's EMS (Easy Maintenance System) has been used to ensure the excavator is always at the forefront of any work site. Special bushes keep joints lubricated and prevent rattling, and help give parts like bushes and pins a longer operating life. This extends the greasing interval of joints like around the bucket and other sections, thereby reducing the amount of maintenance required.

**Greasing interval for bucket:** **250 hours**  
**Greasing interval for other sections:** **1,000 hours**

\* The greasing interval varies depending on operating conditions.



Attachment EMS bushing with self-lubricating capability

Bucket EMS bushing (steel) with excellent wear resistance

## Tough Boom and Arm

The boom and arm are essential for operations, so high-load sections of feature optimised shapes and structures to ensure ample strength and durability. Joints have also been designed for greater reliability.

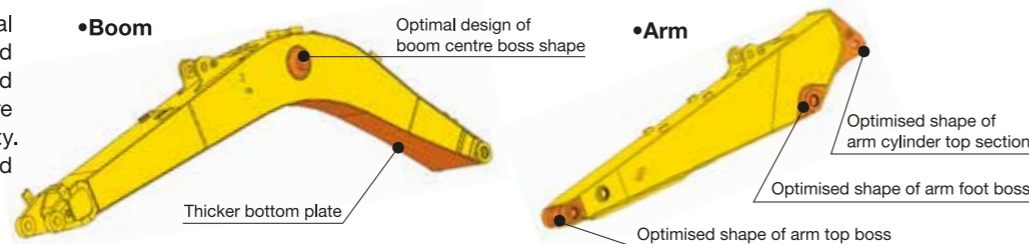

## Superior Undercarriage Cleanout

A linear angled shape for the upper side frame is designed to make it easier to clean out debris from the undercarriage.

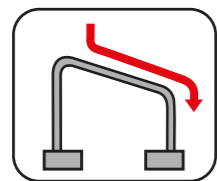

■ Upper side frame shape  
Image has been simplified for illustration purposes.

## Newly Designed Undercarriage for Enhanced Durability and Easier Maintenance

A new undercarriage has been developed featuring improvements to each section for increased durability, with the rollers positioned to reduce vibrations during travelling. The angle of the mounting frame has also been changed for easier sediment cleaning.

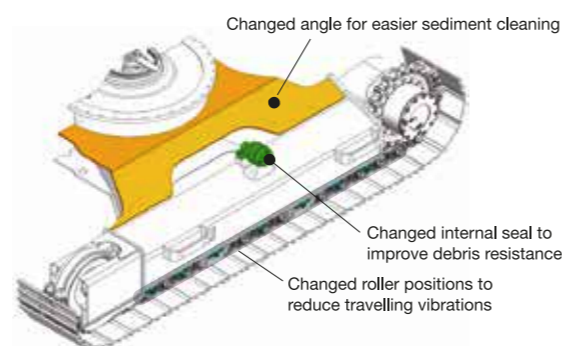

# Specifications

## SH130-7 Technical Data

The electronic-controlled engine of SPACE 5 and SIH:Sa with New Hydraulic System Includes: three working modes (SP, H and A), one-touch/automatic idling system, automatic power-boost, speed assistance system, power-swing system.

### Engine

SH130-7	
Model	ISUZU VD-4JJ1X
Type	Water-cooled, 4-cycle diesel, 4-cylinder in line, high pressure common rail system (electric control), turbocharger with air cooled intercooler, ATS
Rated output	76.4 kW at 2,000 min <sup>-1</sup>
Maximum torque	348 N-m at 1,800 min <sup>-1</sup>
Piston displacement	2,999 ltr (2,999 cc)
Bore and stroke	95.4 mm x 104.9 mm
Starting system	24 V electric motor starting
Alternator	24 V, 90 A
Air filter	Double element

### Hydraulic pumps

Two variable displacement axial piston pumps provide power for boom/arm/bucket, swing, and travel. One gear pump for pilot controls.

SH130-7	
Maximum oil flow	2 x 129 ltr/min
Pilot pump max. oil flow	20 ltr/min

### Hydraulic motors

For travel: Two variable displacement axial piston motors  
For swing: One fixed displacement axial piston motor

### Working circuit pressure

Boom/arm/bucket ... 34.3 MPa  
Boom/arm/bucket ... 36.3 MPa with auto power-up  
Swing circuit ..... 27.9 MPa  
Travel circuit ..... 34.3 MPa

### Control valve

With boom/arm holding valve  
One 4-spool valve for right track travel, bucket, boom and arm acceleration  
One 5-spool valve for left track travel, auxiliary, swing, boom acceleration and arm

### Oil filtration

Return filter ..... 6 microns  
Pilot filter ..... 8 microns  
Suction filter ..... 105 microns

### Hydraulic cylinders

SH130-7		
Cylinder	Q'ty	Bore x rod diameter x stroke
Boom	2	105 mm x 70 mm x 961 mm
Arm	1	115 mm x 80 mm x 1,108 mm
Bucket	1	95 mm x 65 mm x 881 mm

Double-acting, bolt-up type cylinder tube-end; hardened steel bushings  
Installed in cylinder tube and rods ends.

### Cabin & controls

The cabin is mounted on four fluid mountings. Features include safety glass front, rear and side windows, adjustable upholstered suspension seat with headrest and armrest, cigarette lighter, pop-up skylight window, and intermittent wiper with washer. The front window slides upward for storage, and the lower front window is removable. Control levers are located in four positions with tilting control consoles. Built-in type full-colour monitor display. Membrane switch on monitor display.

### Swing

Planetary reduction is powered by an axial piston motor. The internal ring gear has a grease cavity for pinion. The swing bearing is a single-row shear type ball bearing. Dual stage relief valves are used for smooth swing deceleration and stops. A mechanical disc swing brake is included.

SH130-7	
Swing speed	0 ~ 14.3 min <sup>-1</sup>
Tail swing radius	2,170 mm
Swing torque	33 kN -m

### Undercarriage

An X-style carbody is integrally welded for strength and durability. The grease cylinder track adjusters have shock absorbing springs. The undercarriage has lubricated rollers and idlers.

### Type of shoe: sealed link shoe

#### Upper rollers -

Heat treated, mounted on steel bushings with leaded tin bronze casting, sealed for lifetime lubrication.

#### Lower rollers -

Heat treated, mounted on steel bushings with leaded tin bronze casting, sealed for lifetime lubrication.

#### Track adjustment -

Idler axles adjusted with grease cylinder integral with each side frame; adjustment yoke mechanism fitted with heavy duty recoil spring.

### Number of rollers and shoes on each side

SH130-7	
Upper rollers	1
Lower rollers	7
Track shoes	43

### Travel system

Two-speed independent hydrostatic system with compact axial motors for increased performance. Hydraulic motor powered output shaft coupled to a planetary reduction unit and track sprocket. All hydraulic components mounted within the width of side frame. Travel speed can be selected by the switch panel on the monitor display. Hydraulically released disc parking brake is built into each motor.

SH130-7		
Travel speed	High	5.6 km/h
	Low	3.4 km/h
Drawbar pull	116 kN	

### Lubricant & coolant capacity

SH130-7	
Hydraulic system	157 ltr
Hydraulic oil tank	82 ltr
Fuel tank	260 ltr
Cooling system	18 ltr
Final drive case (per side)	2.1 ltr
Swing drive case	2.2 ltr
Engine crank case	17 ltr
Urea water tank	75 ltr

### Auxiliary hydraulic system

SH130-7			
Auxiliary piping type (option)	For Breaker	For Double (breaker & crusher) acting	For D/A + Second option line
Arm type	HD	HD	HD
Bucket linkage type	HD	HD	HD
Auxiliary hydraulic pump flow	129 ltr/min	258 ltr/min	258+55 ltr/min



# Specifications

## Bucket

Options and specifications may differ depending on countries and regions

Model		SH130-7			
Bucket capacity (ISO/SAE/PCSA heaped)		0.5 m <sup>3</sup>	0.55 m <sup>3</sup>	0.55 m <sup>3</sup>	0.65 m <sup>3</sup>
Bucket type		STD Horizontal-pin	STD Horizontal-pin	Reinforced Horizontal-pin	STD Horizontal-pin
Number of teeth		4	5	5	5
Width	With side cutter	972 mm	1,057 mm	1,057 mm	1,192 mm
	Without side cutter	898 mm	983 mm	983 mm	1,118 mm
Weight		388 kg	419 kg	474 kg	450 kg
Combination	2.11 m arm	○	●		○
	2.50 m arm	●		○	△
	3.01 m arm	●		×	×

- Suitable for materials with density up to 2,000 kg/m<sup>3</sup> or less
- Standard bucket (suitable for materials with density up to 1,800 kg/m<sup>3</sup> or less)
- Suitable for materials with density up to 1,600 kg/m<sup>3</sup> or less

- △ Suitable for loading
- ×

## Weight & ground pressure

Model		SH130-7			
Shoe type		Shoe width	Overall width	Operating weight	Ground pressure
Triple grouser shoe		600 mm	2,590 mm	13,200 kg	37 kPa
		700 mm	2,690 mm	13,500 kg	31 kPa

Model		SH130-7 with blade			
Shoe type		Shoe width	Overall width	Operating weight	Ground pressure
Triple grouser shoe		500 mm	2,540 mm	13,900 kg	45 kPa

## Digging force

Model		SH130-7			
Arm length		2.11 m	2.50 m	3.01 m	
Bucket digging force (with auto power up)	ISO 6015	90 kN <95 kN>	90 kN <95 kN>	90 kN <95 kN>	
Arm digging force (with auto power up)	ISO 6015	70 kN <74 kN>	62 kN <66 kN>	56 kN <59 kN>	

## Lifting Capacity

- Notes: 1. Ratings are based on ISO 10567
2. Lifting capacity does not exceed 75% of tipping load with the machine on firm, level ground or 87% full hydraulic capacity.
3. The load point is a arm top.
4. \*Indicates load limited by hydraulic capacity.
5. 0 m = Ground.

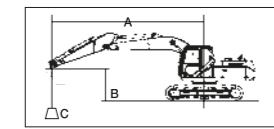

A: Radius of load  
B: Arm top height  
C: Lifting capacity



Unit: kg

### SH130-7

SHOE : 600 (mm) G  
MAXIMUM REACH : 6.76 (m)  
ARM LENGTH : 2.11 (m)  
COUNTERWEIGHT : 1,970 (kg)  
BLADE : —  
BOOM : 4.63 (m)

Arm Top Height	Radius of Load															
	Max. Radius		6 m		5 m		4 m		3 m		2 m		Min. Radius			
	Icon	Icon	Icon	Icon	Icon	Icon	Icon	Icon	Icon	Icon	Icon	Icon	Icon	Icon		
	(kg)	(m)	(kg)	(m)	(kg)	(m)	(kg)	(m)	(kg)	(m)	(kg)	(m)	(kg)	(m)		
6 m	2 740*	5.00	2 740*	5.00			3 600*	3 600*					3 570*	3.82	3 570*	3.82
5 m	2 530*	5.76	2 410	5.76			3 700*	3 070	3 730*	3 730*			3 760*	3.63	3 760*	3.63
4 m	2 450*	6.27	2 080	6.27	3 140	2 240	3 930*	3 010	4 270*	4 260	4 910*	4 910*	5 250*	2.67	5 250*	2.67
3 m	2 440*	6.59	1 890	6.59	3 090	2 200	4 100	2 910	5 080*	4 050	6 690*	6 300	7 600*	2.70	7 480	2.70
2 m	2 500*	6.74	1 800	6.74	3 030	2 140	3 980	2 790	5 610	3 840			7 350*	3.06	5 640	3.06
1 m	2 510	6.74	1 770	6.74	2 970	2 090	3 870	2 690	5 420	3 670			4 930*	3.06	4 930*	3.06
0 m	2 570	6.58	1 810	6.58	2 920	2 050	3 800	2 620	5 310	3 570	5 960*	5 480	4 020*	2.68	4 020*	2.68
-1 m	2 750	6.26	1 930	6.26	2 910	2 040	3 760	2 590	5 280	3 540	8 700	5 480	4 570*	1.68	3 890*	1.68
-2 m	3 120	5.74	2 180	5.74			3 780	2 600	5 290	3 550	8 600*	5 530	7 920*	1.24	6 460*	1.24
-3 m	3 900	4.97	2 710	4.97					5 370	3 620	7 470*	5 630	9 910*	1.58	10 680*	1.58

### SH130-7

SHOE : 600 (mm) G  
MAXIMUM REACH : 7.11 (m)  
ARM LENGTH : 2.50 (m)  
COUNTERWEIGHT : 1,970 (kg)  
BLADE : —  
BOOM : 4.63 (m)

Arm Top Height	Radius of Load																			
	Max. Radius		7 m		6 m		5 m		4 m		3 m		2 m		1 m		Min. Radius			
	Icon	Icon	Icon	Icon	Icon	Icon	Icon	Icon	Icon	Icon	Icon	Icon	Icon	Icon	Icon	Icon	Icon			
	(kg)	(m)	(kg)	(m)	(kg)	(m)	(kg)	(m)	(kg)	(m)	(kg)	(m)	(kg)	(m)	(kg)	(m)	(kg)	(m)		
7 m	2 480*	4.43	2 480*	4.43					3 440*	3 440*							3 420*	3.94	3 420*	3.94
6 m	2 190*	5.47	2 190*	5.47				3 350*	3 110								3 170*	4.21	3 170*	4.21
5 m	2 050*	6.17	2 050*	6.17			2 740*	2 280	3 340*	3 100							3 290*	4.05	3 290*	4.05
4 m	1 990*	6.65	1 890	6.65			3 150	2 260	3 600*	3 030	3 820*	3 820*					4 040*	3.36	4 040*	3.36
3 m	1 990*	6.95	1 730	6.95			3 100	2 200	4 040*	2 920	4 640*	4 110	5 860*	5 860*			7 630*	2.34	7 630*	2.34
2 m	2 040*	7.09	1 650	7.09	2 380	1 680	3 020	2 140	3 990	2 800	5 570*	3 870	7 770*	5 940			7 090*	2.75	6 790	2.75
1 m	2 140*	7.09	1 620	7.09	2 350	1 650	2 950	2 070	3 870	2 690	5 440	3 680	6 410*	5 590			4 240*	2.74	4 240*	2.74
0 m	2 320*	6.94	1 650	6.94			2 900	2 020	3 780	2 600	5 300	3 550	6 710*	5 440			3 310*	2.32	3 310*	2.32
-1 m	2 500	6.64	1 750	6.64			2 870	1 990	3 730	2 550	5 230	3 490	8 620*	5 400	4 630*	4 630*	3 400*	0.99	3 400*	0.99
-2 m	2 790	6.15	1 940	6.15			2 880	2 000	3 720	2 550	5 230	3 490	8 650	5 430	7 150*	7 150*	5 560*	0.85	5 470*	0.85
-3 m	3 360	5.44	2 330	5.44					3 770	2 590	5 280	3 540	8 000*	5 510	10 390*	10 390*		1.13	8 180*	1.13
-4 m	4 070*	4.39	3 240	4.39							4 740*	3 670	6 360*	5 680			8 340*	2.08	8 340*	2.08

### SH130-7

SHOE : 600 (mm) G  
MAXIMUM REACH : 7.57 (m)  
ARM LENGTH : 3.01 (m)  
COUNTERWEIGHT : 1,970 (kg)  
BLADE : —  
BOOM : 4.63 (m)

Arm Top Height	Radius of Load																			
	Max. Radius		7 m		6 m		5 m		4 m		3 m		2 m		1 m		Min. Radius			
	Icon	Icon	Icon	Icon	Icon	Icon	Icon	Icon	Icon	Icon	Icon	Icon	Icon	Icon	Icon	Icon	Icon			
	(kg)	(m)	(kg)	(m)	(kg)	(m)	(kg)	(m)	(kg)	(m)	(kg)	(m)	(kg)	(m)	(kg)	(m)	(kg)	(m)		
7 m	2 210*	5.14	2 210*	5.14					2 550*	2 550*							2 920*	4.50	2 920*	4.50
6 m	1 990*	6.06	1 990*	6.06					2 170*	2 170*	2 830*	2 830*					2 760*	4.71	2 760*	4.71
5 m	1 890*	6.70	1 890*	6.70					3 030*	2 330	2 890*	2 890*					2 830*	4.59	2 830*	4.59
4 m	1 850*	7.14	1 690	7.14	2 320*	1 760	3 150*	2 300	3 190*	3 090							3 240*	4.06	3 240*	4.06
3 m	1 850*	7.42	1 560	7.42	2 440	1 730	3 130	2 230	3 650*	2 970	4 060*	4 060*	4 820*	4 820*			5 350*	2.58	5 350*	2.58
2 m	1 900*	7.55	1 490	7.55	2 390	1 690	3 040	2 150	4 030	2 830	5 040*	3 950	6 770*	6 150			7 730*	2.69	7 330	2.69
1 m	1 990*	7.55	1 460	7.55	2 350	1 650	2 960	2 070	3 890	2 700	5 500	3 720	8 390*	5 700			5 660*	2.68	5 660*	2.68
0 m	2 130	7.41	1 480	7.41	2 310	1 610	2 890	2 010	3 780	2 600	5 310	3 560	7 430*	5 450			3 560*	2.24	3 560*	2.24
-1 m	2 230	7.13	1 550	7.13	2 290	1 590	2 840	1 970	3 700	2 530	5 210	3 470	8 390*	5 350	4 420*	4 420*	3 080*	0.72	2 980*	0.72
-2 m	2 450	6.68	1 700	6.68			2 830	1 950	3 670	2 500	5 170	3 440	8 550	5 340	6 340*	6 340*	4 780*	0.34	4 460*	0.34
-3 m	2 850	6.04	1 970	6.04			2 870	1 990	3 690	2 520	5 200	3 460	8 540*	5 400	8 830*	8 830*	6 730*	0.57	6 290*	0.57
-4 m	3 680	5.11	2 540	5.11					3 790	2 610	5 290	3 540	7 310*	5 520	10 180*	10 180*		1.25	9 800*	1.25



Notes: 1. Ratings are based on ISO 10567

- Lifting capacity does not exceed 75% of tipping load with the machine on firm, level ground or 87% full hydraulic capacity.
- The load point is a arm top.
- \*Indicates load limited by hydraulic capacity.
- 0 m = Ground.

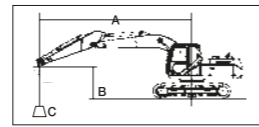

A: Radius of load  
B: Arm top height  
C: Lifting capacity



Unit: kg

### SH130-7

SHOE : 500 (mm) G  
MAXIMUM REACH : 6.76 (m)  
ARM LENGTH : 2.11 (m)  
COUNTERWEIGHT : 1,970 (kg)  
BLADE : UP  
BOOM : 4.63 (m)

Arm Top Height	Max. Radius		6 m		5 m		4 m		3 m		2 m		Min. Radius					
	(kg)	(m)	(kg)	(m)	(kg)	(m)	(kg)	(m)	(kg)	(m)	(kg)	(m)	(kg)	(m)				
6 m	2 740*	5.00	2 740*	5.00					3 600*	3 600*			3 570*	3.82	3 570*	3.82		
5 m	2 530*	5.76	2 530*	5.76					3 700*	3 230	3 730*	3 730*		3 760*	3.63	3 760*	3.63	
4 m	2 450*	6.27	2 200	6.27	3 100	2 370	3 930*	3 160	4 270*	4 270*	4 910*	4 910*		5 250*	2.67	5 250*	2.67	
3 m	2 440*	6.59	2 000	6.59	3 060	2 330	4 060	3 060	5 080*	4 270	6 690*	6 620		7 600*	2.70	7 600*	2.70	
2 m	2 500*	6.74	1 910	6.74	3 000	2 270	3 940	2 950	5 560	4 050				7 350*	3.06	5 950	3.06	
1 m	2 480	6.74	1 880	6.74	2 940	2 210	3 830	2 850	5 370	3 880				4 930*	3.06	4 930*	3.06	
0 m	2 550	6.58	1 920	6.58	2 890	2 170	3 760	2 780	5 260	3 780	5 960*	5 800		4 020*	2.68	4 020*	2.68	
-1 m	2 720	6.26	2 050	6.26	2 880	2 160	3 720	2 750	5 220	3 750	8 610	5 800	4 570*	4 570*	3 890*	1.68	3 890*	1.68
-2 m	3 090	5.74	2 320	5.74			3 740	2 760	5 240	3 760	8 600*	5 850	7 920*	7 920*	6 460*	1.24	6 460*	1.24
-3 m	3 860	4.97	2 870	4.97					5 320	3 830	7 470*	5 950	9 910*	9 910*	10 680*	1.58	10 680*	1.58

### SH130-7

SHOE : 500 (mm) G  
MAXIMUM REACH : 7.11 (m)  
ARM LENGTH : 2.50 (m)  
COUNTERWEIGHT : 1,970 (kg)  
BLADE : UP  
BOOM : 4.63 (m)

Arm Top Height	Max. Radius		7 m		6 m		5 m		4 m		3 m		2 m		1 m		Min. Radius					
	(kg)	(m)	(kg)	(m)	(kg)	(m)	(kg)	(m)	(kg)	(m)	(kg)	(m)	(kg)	(m)	(kg)	(m)	(kg)	(m)				
7 m	2 480*	4.43	2 480*	4.43							3 440*	3 440*					3 420*	3.94	3 420*	3.94		
6 m	2 190*	5.47	2 190*	5.47							3 350*	3 270					3 170*	4.21	3 170*	4.21		
5 m	2 050*	6.17	2 050*	6.17			2 740*	2 400	3 340*	3 260							3 290*	4.05	3 290*	4.05		
4 m	1 990*	6.65	1 990*	6.65			3 120	2 390	3 600*	3 190	3 820*	3 820*					4 040*	3.36	4 040*	3.36		
3 m	1 990*	6.95	1 840	6.95			3 060	2 330	4 040*	3 080	4 640*	4 320	5 860*	5 860*			7 630*	2.34	7 630*	2.34		
2 m	2 040*	7.09	1 750	7.09	2 360	1 790	2 990	2 260	3 950	2 960	5 570*	4 080	7 770*	6 260			7 090*	2.75	7 090*	2.75		
1 m	2 140*	7.09	1 720	7.09	2 320	1 750	2 920	2 200	3 830	2 840	5 380	3 890	6 410*	5 910			4 240*	2.74	4 240*	2.74		
0 m	2 320*	6.94	1 750	6.94			2 870	2 150	3 740	2 760	5 240	3 760	6 710*	5 760			3 310*	2.32	3 310*	2.32		
-1 m	2 470	6.64	1 860	6.64			2 840	2 120	3 690	2 710	5 180	3 700	8 530	5 720	4 630*	4 630*	3 400*	3 400*	3 400*	0.99	3 400*	0.99
-2 m	2 760	6.15	2 070	6.15			2 850	2 130	3 680	2 710	5 170	3 700	8 560	5 750	7 150*	7 150*	5 560*	5 560*	5 470*	0.85	5 470*	0.85
-3 m	3 320	5.44	2 470	5.44					3 730	2 750	5 230	3 750	8 000*	5 840	10 390*	10 390*			8 180*	1.13	8 180*	1.13
-4 m	4 070*	4.39	3 420	4.39							4 740*	3 880	6 360*	6 000			8 340*	2.08	8 340*	2.08		

### SH130-7

SHOE : 500 (mm) G  
MAXIMUM REACH : 7.57 (m)  
ARM LENGTH : 3.01 (m)  
COUNTERWEIGHT : 1,970 (kg)  
BLADE : UP  
BOOM : 4.63 (m)

Arm Top Height	Max. Radius		7 m		6 m		5 m		4 m		3 m		2 m		1 m		Min. Radius					
	(kg)	(m)	(kg)	(m)	(kg)	(m)	(kg)	(m)	(kg)	(m)	(kg)	(m)	(kg)	(m)	(kg)	(m)	(kg)	(m)				
7 m	2 210*	5.14	2 210*	5.14													2 920*	4.50	2 920*	4.50		
6 m	1 990*	6.06	1 990*	6.06													2 760*	4.71	2 760*	4.71		
5 m	1 890*	6.70	1 890*	6.70													2 830*	4.59	2 830*	4.59		
4 m	1 850*	7.14	1 790	7.14	2 320*	1 860	3 150*	2 420	3 190*	3 190*							3 240*	4.06	3 240*	4.06		
3 m	1 850*	7.42	1 660	7.42	2 410	1 840	3 100	2 360	3 650*	3 130	4 060*	4 060*	4 820*	4 820*			5 350*	2.58	5 350*	2.58		
2 m	1 900*	7.55	1 580	7.55	2 370	1 790	3 010	2 280	3 990	2 990	5 040*	4 170	6 770*	6 470			7 730*	2.69	7 710	2.69		
1 m	1 990*	7.55	1 560	7.55	2 320	1 750	2 930	2 200	3 850	2 860	5 440	3 940	8 390*	6 020			5 660*	2.68	5 660*	2.68		
0 m	2 100	7.41	1 580	7.41	2 280	1 710	2 860	2 140	3 740	2 760	5 260	3 770	7 430*	5 770			3 560*	2.24	3 560*	2.24		
-1 m	2 210	7.13	1 660	7.13	2 260	1 700	2 810	2 090	3 660	2 690	5 150	3 680	8 390*	5 670	4 420*	4 420*	3 080*	3 080*	2 980*	0.72	2 980*	0.72
-2 m	2 420	6.68	1 810	6.68			2 800	2 080	3 630	2 660	5 120	3 650	8 460	5 660	6 340*	6 340*	4 780*	4 780*	4 460*	0.34	4 460*	0.34
-3 m	2 810	6.04	2 100	6.04			2 840	2 110	3 650	2 680	5 140	3 670	8 520	5 720	8 830*	8 830*	6 730*	6 730*	6 290*	0.57	6 290*	0.57
-4 m	3 640	5.11	2 690	5.11					3 750	2 760	5 240	3 750	7 310*	5 840	10 180*	10 180*			9 800*	1.25	9 800*	1.25

### Principle Specifications

	SH130-7 STD Specifications	SH130-7 with blade STD Specifications
Base		
Boom length		4.63 m
Arm length		2.50 m
Bucket capacity (ISO heaped)	0.5 m <sup>3</sup>	0.5 m <sup>3</sup>
Std. operating weight	13,200 kg	13,900 kg
Engine		ISUZU VD-4JJ1X
Make & model		
Rated output		76.4 kW/2,000 min <sup>-1</sup>
Displacement		2,999 ltr
Hydraulic System		
Main pump		2 variable displacement axial piston pumps with regulating system
Max. pressure		34.3 MPa
/with auto power boost		36.3 MPa
Travel motor		Variable displacement axial piston motor
Parking brake type		Mechanical disc brake
Swing motor		Fixed displacement axial piston motor
Performance		
Travel speed (high/low)		5.6/3.4 km/h
Drawbar pull		116 kN
Gradeability		70% <35°>
Ground pressure	37 kPa	45 kPa
Swing speed		14.3 min <sup>-1</sup>
Bucket digging force		90 kN
/with power boost		95 kN
Arm digging force		62 kN
/with power boost		66 kN
Others		
Fuel tank		260 ltr
Hydraulic fluid tank		82 ltr
Urea water tank		75 ltr

### Working Range

	SH130-7		
Arm length	2.11 m	2.50 m	3.01 m
Boom length	4.63 m		
A Max. digging radius	7,990 mm	8,340 mm	8,800 mm
B Max. digging depth	5,180 mm	5,560 mm	6,080 mm
C Max. digging height	8,580 mm	8,800 mm	9,080 mm
D Max. dumping height	6,140 mm	6,360 mm	6,650 mm
E Max. vertical wall cut depth	4,700 mm	4,980 mm	5,380 mm
F Min. front swing radius	2,360 mm	2,340 mm	2,660 mm
G Rear end swing radius	2,170 mm		
H Max. lift above ground	510 mm		
I Min. drop below ground	520 mm		

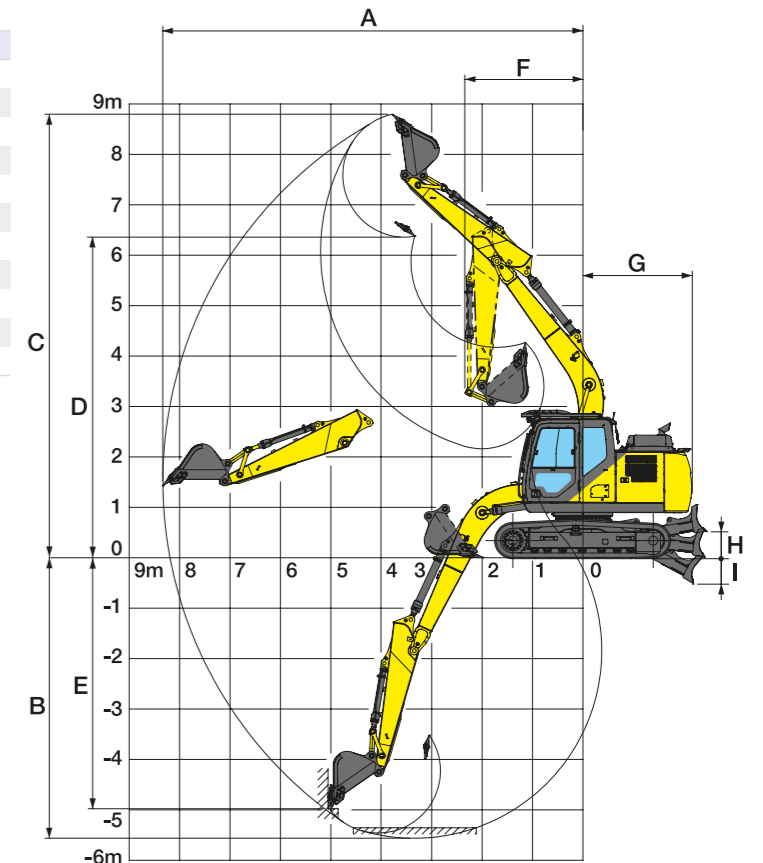



## Standard Equipment

### [Hydraulic system]

- SIH: S a hydraulic system
- Operation mode (SP, H and A mode)
- Automatic 2-speed travel
- Automatic power boost
- Boom/arm holding valve
- Arm/boom/bucket reactivation circuit
- Automatic swing parking system
- Auxiliary valve
- High-performance return filter

### [Cabin/interior equipment]

- 4-point fluid mounts
- New full-colour LCD monitor
- Tilting console
- Fresh-air intake pressurised full-automatic air conditioner
- Defroster
- Hot & cool box
- High water-repellent seat
- Seat suspension
- Armrest & headrest
- Windscreen wiper (with intermittent operation function)
- Cup holder
- Magazine rack
- Accessory case
- Floor mat
- Ashtray & cigarette lighter
- Cab light (Auto-OFF function)
- Coat hook
- Operation lever with one-touch wiper switch
- Polycarbonate roof top window with sunshade
- 12V power (DC-DC converter)

### [Safety equipment]

- ROPS cab (FOPS level 1)
- Head guard (OPG Level 2)
- Rear/right side camera
- Rearview mirror (left/right)
- Emergency escape tool
- Retracting seat belt
- Gate lock lever (engine neutral start)
- Travel alarm
- Anti-theft alarm system
- Engine room firewall
- Fan guard
- Engine emergency stop switch

### [Others]

- Auto/one-touch idling
- Auto idle shutdown system
- EMS
- Long-life hydraulic oil
- Five lights (chassis, left/right of boom, cab)
- Fuel filter (with water separator and clogging sensor)
- Fuel pre-filter (with water separator)
- Double-element air cleaner
- Grease-enclosed track link
- Large tool box
- A set of tools
- Pre-air cleaner

## Accessories (option)

### ■ Cab-top lights (LED)



### ■ Camera lights (LED) (top: side, bottom: rear)



### ■ Rain deflector



### ■ Sun visor



### ■ Front mesh guard (full)



### ■ Front guard (OPG level 1 or 2)



### ■ Blade

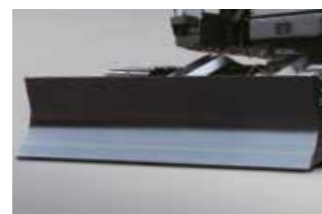

### ■ Refuel pump

### ■ Hose burst check valve (HBCV) for boom/arm cylinders

### ■ Double track guard

Accessories and specifications may differ depending on countries and regions.

## Dimensions

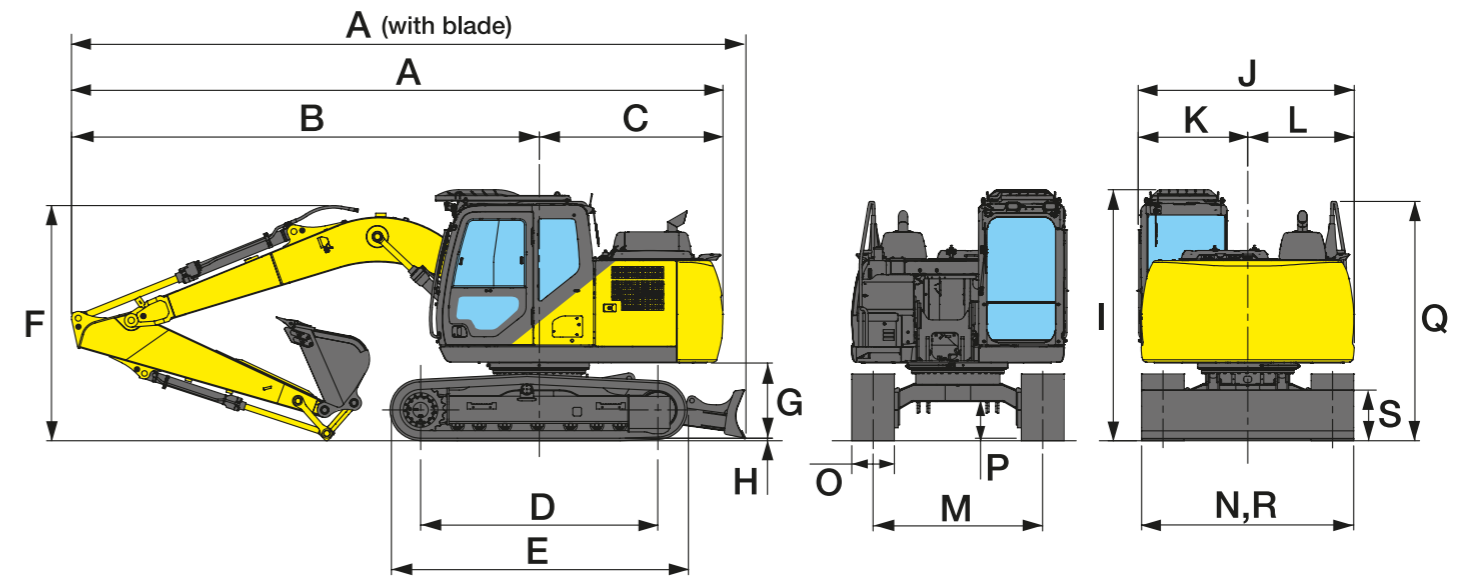

Model	SH130-7		
Arm length	2.11 m	2.50 m	3.01 m
A Overall length	7,640 mm	7,650 mm	7,670 mm
B Length from centre of machine (to arm top)	5,480 mm	5,490 mm	5,510 mm
C Length from centre of machine (to rear end)		2,160 mm	
D Centre to centre of wheels		2,790 mm	
E Overall track length		3,500 mm	
F Overall height	2,670 mm	2,760 mm	2,740 mm
G Clearance height under upper structure		890 mm	
H Shoe lug height		20 mm	
I Cab height		2,950 mm	
J Upper structure overall width		2,540 mm	
K Width from centre of machine (left side)		1,290 mm	
L Width from centre of machine (right side)		1,250 mm	
M Track gauge		1,990 mm	
N Overall width		2,590 mm	
O Std. shoe width		600 mm	
P Minimum ground clearance		430 mm	
Q Handrail height		2,810 mm	

Model	SH130-7 with blade		
Arm length	2.11 m	2.50 m	3.01 m
A Overall length	7,910 mm	7,920 mm	7,940 mm
B Length from centre of machine (to arm top)	5,480 mm	5,490 mm	5,510 mm
C Length from centre of machine (to rear end)		2,160 mm	
D Centre to centre of wheels		2,790 mm	
E Overall track length		3,500 mm	
F Overall height	2,670 mm	2,760 mm	2,740 mm
G Clearance height under upper structure		890 mm	
H Shoe lug height		20 mm	
I Cab height		2,950 mm	
J Upper structure overall width		2,540 mm	
K Width from centre of machine (left side)		1,290 mm	
L Width from centre of machine (right side)		1,250 mm	
M Track gauge		1,990 mm	
N Overall width		2,490 mm	
O Std. shoe width		500 mm	
P Minimum ground clearance		430 mm	
Q Handrail height		2,810 mm	
R Width of blade		2,490 mm	
S Height of blade		570 mm	