

SUMITOMO EXCAVATORS

SH210-7 SH220LC-7

- Engine Rated Power (Net): 119.3 kW
- Operating Weight:
 - SH210-7 22,200 kg
 - SH220LC-7 22,500 kg
- Bucket Capacity (ISO Heaped): 1.0 m³

HYDRAULIC EXCAVATOR FOR REAL PERFORMANCE

LEGEST

SUMITOMO

SH210/220LC-7 Hydraulic Excavator

 **SUMITOMO CONSTRUCTION
MACHINERY CO., LTD.**

731-1 Naganumahara-cho, Inage-ku, Chiba, 263-0001 Japan
For further information please contact: Phone : +81-43-420-1829 Facsimile : +81-43-420-1907

We are constantly improving our products and therefore reserve the right to change designs and specifications without notice.
Illustrations may include optional equipment and accessories and may not include all standard equipment.



EU Stage V

Advances Abound. Innovation Infinite.

Setting a new bar for worksite proficiencies. The All-new LEGEST.

The new LEGEST series from Sumitomo has been developed to exceed its own capabilities in every regard, with performance benchmarks that will stand the test of time and innovation to tackle any job. Created for more seamless operations in an extensive range of worksite surroundings, both businesses and operators will come to treasure the performance the LEGEST is capable of providing. Unleash the potential on your worksite with capabilities never before seen.

LEGEST

Advanced Energy Efficiency and Eco-friendly Operation 04-07

- Clean and Fuel-efficient Engine "SPACE 5 α"
- Innovative Hydraulic System "SIH:S α"
- SUMITOMO Technology for Fuel Efficiency

Unparalleled Performance 08-09

Advanced Operator Comfort 10-11

- New Monitor
- New Air Suspension Seat

Sophisticated Safety Features 12-13

- Rear and Right Side Camera

Superior Ease-of-maintenance and Durability 14-16

- Ground Level Access
- EMS

Specifications 17-23

Advanced Energy Efficiency and Eco-friendly Operation

The combination of the advanced clean engine "SPACE 5 α" and SUMITOMO's proprietary hydraulic system "SIH:S α" achieves much higher operating efficiency and superior fuel economy. These features also mean the excavator is even easier on the environment and worksites.

Faster Operations and Excellent Fuel Economy!

Clean engine **SPACE 5 α** × Innovative hydraulic system **SIH:S α** = **7%* less fuel consumption**

* Comparison of fuel consumption with same workload (SH210-7 SP mode compared against SH210-6 SP mode). The level of reduction may be less than shown above depending on actual job type.

Meets EU Stage V standards

The clean engine "SPACE 5 α" achieves significant reductions in exhaust gas emissions, meeting European Stage V non-road emission standards (EU Stage V), deemed the toughest emissions standards in the world. The SH210-7 series excavator has been designed to be even more environmentally friendly.

NOx: 90% reduction
PM: 95% reduction
(compared to SH210-6)

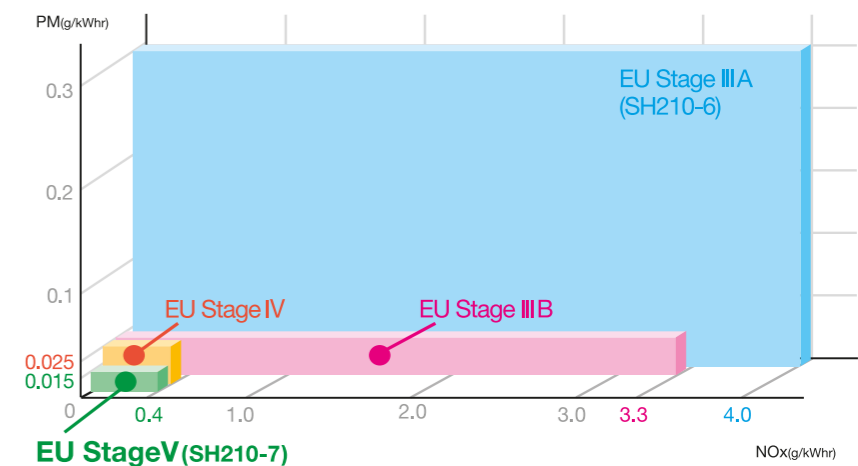

Clean and Fuel-efficient Engine "SPACE 5 α"

The SH210-7 is powered by a new engine designed for significantly improved combustion efficiency and much lower fuel consumption. In addition to a common rail fuel injection system designed for optimum fuel injection, a cooled EGR and VG turbocharger help to achieve cleaner exhaust gas emissions as well as superior power and response.

Exhaust After Treatment System (ATS)

An advanced exhaust after treatment system has been used, featuring a combination of a ceramic filter and SCR. The pre-stage ceramic filter removes PM through collection and combustion, while the post-stage SCR injects AdBlue® (urea water) into the exhaust gas, cleaning the NOx into harmless nitrogen and water through chemical reaction. Post treatment of NOx allows for high-efficiency combustion at the engine, achieving superior clean running as well as powerful and low fuel consumption operation.

AdBlue® is a registered trademark of the German Association of the Automotive Industry.

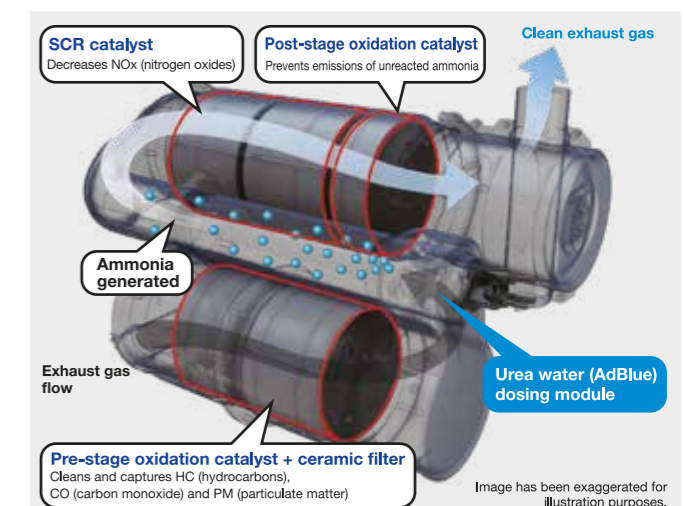

SCR System Design

The SCR system comprises an oxidation catalyst, SCR catalyst and urea water dosing module. The urea water is injected into the exhaust gas, where the NOx is reduced by the SCR catalyst and ammonia generated from the urea water and broken down into harmless nitrogen and water, resulting in clean exhaust gases.

SCR: Selective Catalytic Reduction

Gelişmiş Enerji Verimliliği ve Çevre Dostu Çalışma

Yenilikçi Hidrolik Sistem "SIH:S"

Yakıt tüketimini azaltmak için yenilikçi bir hidrolik sistem kullanılırken, tamamen elektronik bir kontrollü hidrolik pompa hassas ow kontrolü sağlar. Ayrıca aşağıdakiler için de geliştirmeler yapılmıştır iş koşullarına uygun optimum hidrolik kontrol için SUMITOMO'nun tescilli Spool Strok Kontrolü, böylece daha da verimli operasyonlar ve önemli ölçüde daha düşük yakıt tüketimi sağlar.

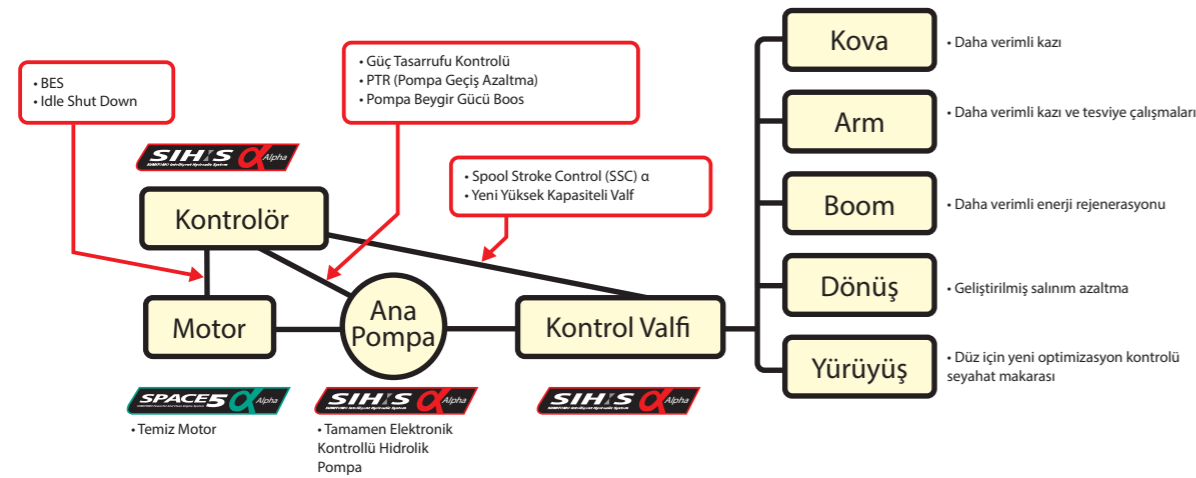

Temiz ve Yakıt Tasarruflu Motor "SPACE 5 α"

Ekonomik Çalışma İçin Üç Farklı Çalışma Modu



Üç çalışma modu mevcuttur: Daha hızlı işler için SP (Super Power) modu, ağır hizmet uygulamaları için H (Heavy) modu ve geniş kullanım ve yakıt verimliliği için A (Auto) modu kullanılmaktadır. Farklı çalışma koşullarına uygun seçilecek modlar ile yüksek verim ile çalışılmaktadır.



Entegre Gaz Kelebeği Modu Seçici

Gaz kelebeği modu sadece düğmeyi çevirerek seçilebilir, böylece herkes kolayca optimum çalışma modunu seçin..

Yakıt Verimliliği Sağlayan SUMITOMO Teknolojileri

• Spool Strok Denetimi (SSC) α

Yakıt tasarrufu için hidrolik basıncı otomatik olarak ayarlar. Daha iyi hassasiyet çalışma koşullarının

• Tam Elektronik Kontrollü Hidrolik Pompa

Hassasiyet için ultra hassas hidrolik basınç algılama teknolojisi ile tasarlanmıştır. Her tür işe uygun hız kontrolü sunar. Bunlar hız elde etmeye yardımcı olur, geliştirir, operasyonları ve yakıt tüketimini azaltır.

• Güç Tasarrufu Kontrolü

Makine çalışmadığında ana pompanın çalışma hızını azaltır, bu da gereksiz yakıt tüketimini azaltır.

• BES (Bom Aşağı Enerji Tasarrufu)

Increases fuel efficiency during boom-down operation.

• PTR (Pompa Geçişinde Düşüş)

Pompa debi gereksinimi ani pompa yükü ile azaldığında motor yükünü düşürür.

• Rölantide Motor Kapatma ve Otomatik Rölanti Özelliği (Idle Shut Down & Auto Idle)

Devreye sokulduktan sonra rölantide kapatma işlevi makineni ayarlanan bir süreyle çalışmaması durumunda motoru otomatik olarak durdurur.



Unparalleled Performance

The Innovative Hydraulic System “SIH:S α” provides a stunning new level of performance on job sites. A fully electronically controlled hydraulic pump enhances engine and pump control, and when combined with SUMITOMO’s proprietary Spool Stroke Control (SSC) α, ensures precision control across the entire operating range. The excavator responds exactly as the operator is expecting, with predictable speed, digging power and movement streamlining work on any job site.

Even faster operations

Advances and optimisations made to the hydraulic control system and the use of large capacity valves to reduce pressure loss help to reduce cycle time in all modes—boosting efficiency for site operations.

SP mode: 2% faster cycle time

H mode: 2% faster cycle time

A mode: 3% faster cycle time

(compared with SH210-6)

Work Efficiency Drastically Increased SUMITOMO UNIQUE DESIGN

Spool Stroke Control (SSC) α provides precision optimal flow rate control to suit operating conditions. Speed, power, operations, and control are exactly as the operator expects, meaning work efficiency is increased dramatically. It now also covers a greater range, with more precise identification of operating type. These all help to achieve an even higher level of energy efficiency and smooth operations.

New High-capacity Control Valve

The valve structure has been improved to significantly reduce pressure loss within internal circuits. Hydraulic oil from the pump is distributed and pumped to actuators efficiently, drastically increasing work speed for both single and combined operations.

Faster Cycle Time and Greater Productivity

Faster operation reduces cycle time, while smooth control of the hydraulics also achieves operability for precision works.

Easier Dump Truck Loading SUMITOMO UNIQUE DESIGN

Loading dump trucks is easier through the combination of SUMITOMO’s proprietary technology and more powerful boom raising during swing operation. This optimizes hydraulic flow in various circuits, making the operation much smoother and quicker.





Advanced Operator Comfort

A comfortable cabin has been designed to reduce operator fatigue, with the aim of relieving stress during work and ensuring greater relaxation during downtime. With features such as a spacious cabin interior, new high-definition monitor with smartphone-like usability, new air suspension seat, and unbelievably quiet operation, the cabin is both comfortable and intuitive to ensure a greater level of safety.

New Monitor—Even More Intuitive and User-friendly

A wide range of excavator operating and maintenance information, warnings and other data are displayed as text messages. Providing a way to view accurate and easy-to-understand information helps to boost operating efficiency and safety.



Illustrations of new monitor displays



Indicators

- 1 Working modes
- 2 Icons
- 3 Warning messages
- 4 Engine coolant temperature
- 5 Fuel level
- 6 Urea water level
- 7 ATS warning
- 8 Camera view (rear camera)
- 9 Camera view (right side camera)

Switch Panel

- A Travel speed button
- B ATS purge
- C Aux. hydraulic settings
- D Window wiper
- E Window washer
- F Work lights
- G Auto idle/Idle stop
- H Display modes
- I Hour meter toggle (trip/total)

Spacious, Class-leading Cabin

Just like previous models, the cabin has been designed with features that are top of its class, all of which help to ensure a comfortable and stress-free space for the operator. Superior sound insulation throughout the cabin translates to top-class levels of silence within.

Console-linked Arm Rest



The arm rest is linked with movement of the tilting console. The distance between the arm rest and operations levers remains the same, regardless of the angle of the console, leading to a greater level of comfort and control.



New Air Suspension Seat

The operator's seat features air suspension as standard for outstanding ride comfort. A new high-performance reclining seat with higher seatback has been used to ensure premium comfort. A multitude of seat adjustments and ample seat cushion width all help to significantly lower operator fatigue. The high water-repellent seat material is also easier to keep clean.



Seat air suspension

Premium Comfort with Seat Heater (OPTION)

A seat heater function is now available as an optional extra for even greater comfort in cold seasons or working early mornings. A convenient seat tilting function has also been added that allows the seat cushion to be tilted forward or back to suit the operator's body type or particular job—now anyone can achieve the optimum seating posture for more comfortable control.



Seat heater switch

Automatic Air-conditioner

Fully automatic climate control maintains a comfortable temperature within the cabin. The optimal ducting layout and airtight cabin also help to boost air-conditioning efficiency.



Equipment for Comfort and Safety



Rear luggage space

Hot & cool box

Magazine rack



Anti-theft system

Emergency stop switch

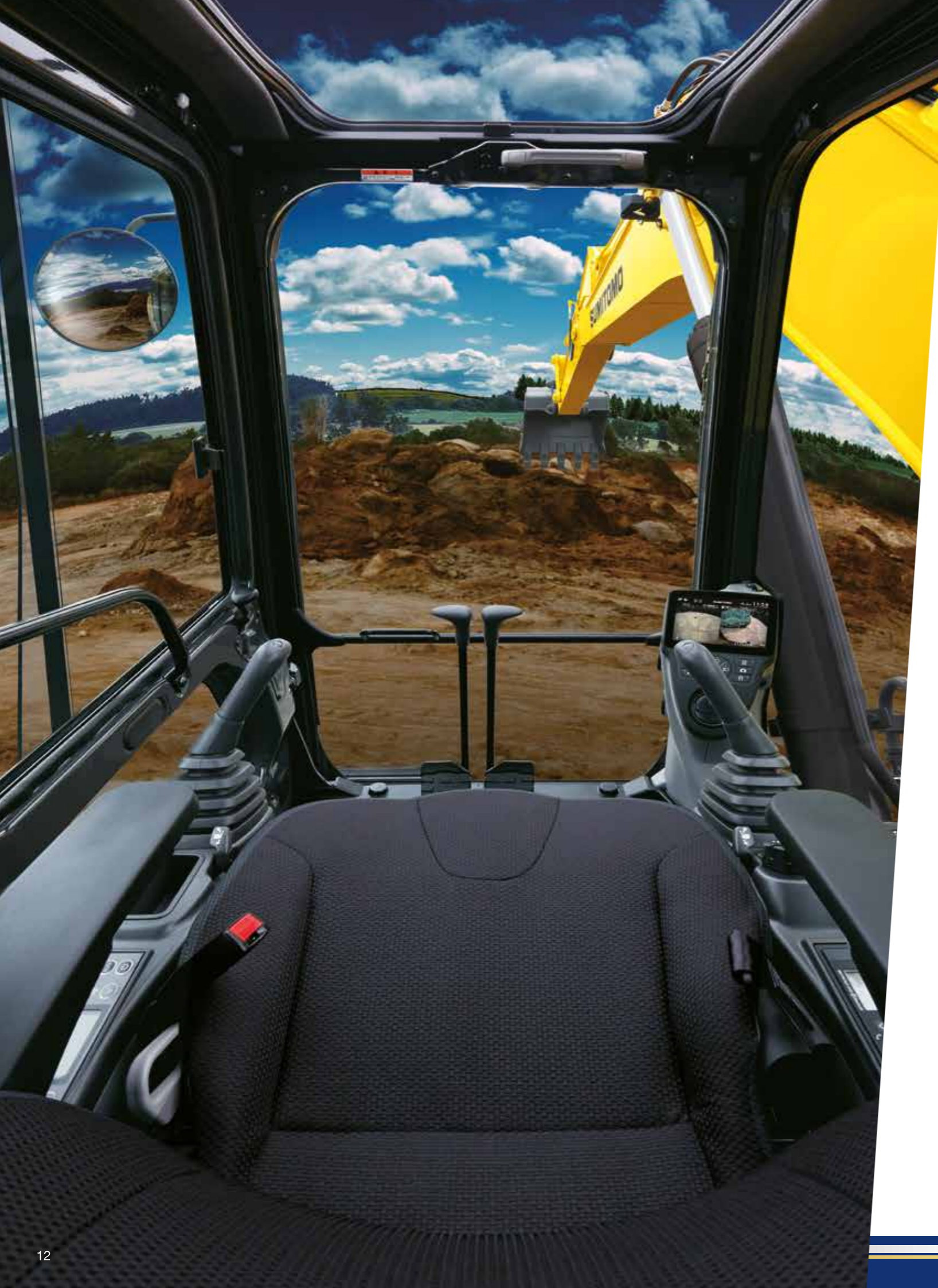

Sophisticated Safety Features

The cabin provides excellent driving visibility, and features a high-strength design to better protect the operator. Every aspect has been designed for day-to-day safety, including excellent access in and out of the cabin, and steps and handrails to make inspections and maintenance easier. The use of rear and right side cameras also helps to ensure operations remain safe.

Safe ROPS-compliant Cabin

A high-strength cabin design means operators are even better protected.

ROPS: Roll-Over Protective Structure

Moulded steel pipe

Square pipe

Thick plate

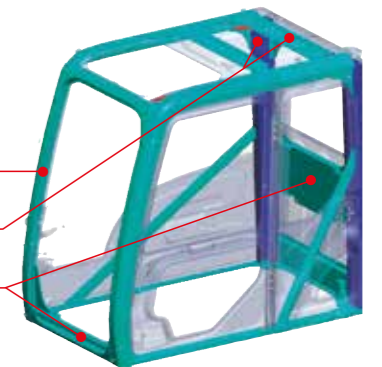

Wide View for Excellent Site Safety

In addition to the front of the excavator, the cabin design gives the operator a wide, unrestricted view to check upper and lower areas. Direct visibility for the operator means work can be performed safer.



Superb Access

The wide door opening and large handrails provide excellent access up to and down from the cabin. The spacious footwell also makes it easier to get in and out.



Large handrail and spacious footwell

Rear and Right Side Cameras

Two cameras are installed as standard—rear view and on the right side—so the operator can check for safety behind the excavator. Optimally positioned mirrors and the use of cameras ensure that mirror visibility meets ISO standards, thus making it easier for the operator to check for safety in any desired direction.



Monitor videos

Handrails and Non-slip Plates for Operator Safety

Steps and handrails are in the optimal positions to assist getting in and out of the cabin and to ensure safety during inspections and maintenance. New handrails have now also been installed at the rear of the cabin and the right side of the body, while non-slip plates improve safety when it is raining.



Handrails

Non-slip plates



Rear camera



Right side camera

LED Cabin Top Light (OPTION)

A long-life LED cabin top light is now available as an optional extra. Super bright and with a high-visibility colour, the light enhances safety during night-time operations.



LED cabin top light



Superior Ease-of-maintenance and Durability

Easy maintenance and durability are the key to excavators that are called upon for ongoing work at job sites. With enhanced durability at every corner and proprietary EMS, outstanding reliability is standard with SUMITOMO excavators—they are designed to be easy to operate and maintain for customers, including features like ground level access and refilling AdBlue®.

Ground Level Access for Easy Inspections and Maintenance

Components requiring inspection are all in a central location, meaning inspections and refilling can be performed without having to climb up onto the excavator.

•Increased Cooling Performance

The use of a larger radiator and oil cooler help to increase cooling performance and reliability. It is also easier to clean the dust-proof net.

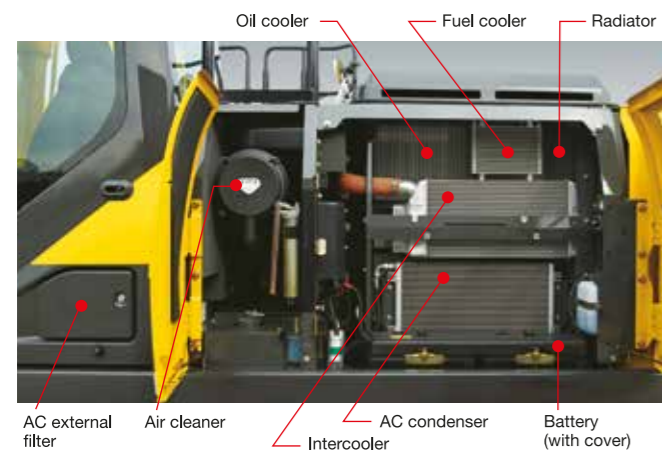

•Designed for Easy Filter Replacement

The pre-fuel filter is designed to reduce issues due to a blocked fuel filter, and the easily accessible location of the fuel and oil filters ensure smooth inspection and replacement work.

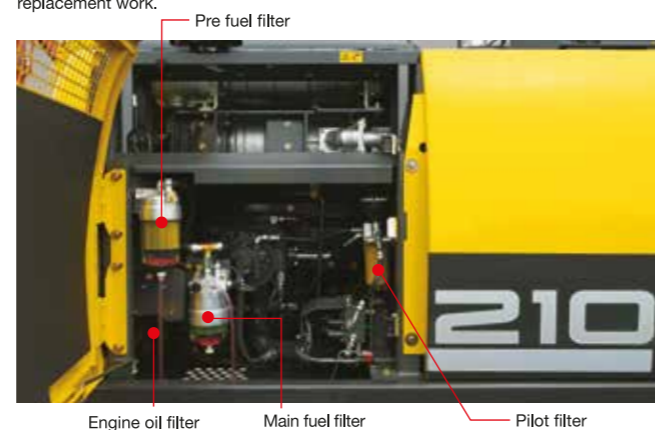

Battery Cutoff Switch

A battery switch is mounted inside the inspection cover, ensuring safe operations during maintenance procedures.



Other Maintenance Features



Central fuse box located behind seat



Easy-access AC filter



Washable cab floor and floor mats

Dust-proof Net for Enhanced Ground Level Access

A dust-proof net mounted on the front of cooling package reduces the amount of dust adhesion, leading to a higher level of reliability. Ground level access means the dust-proof net can be quickly removed for easy cleaning.



Dust-proof net

High-Performance Return Filter

A long hydraulic oil change interval of 5,000 hours, and the use of a high-performance return filter ensures superior ease-of-maintenance.

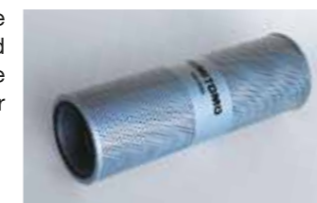

Hydraulic oil change: **5,000** hours
Filter life: **2,000** hours

* The oil and filter change intervals vary depending on operating conditions.

Easy-to-fill Urea Tank

The urea tank has been positioned near the front right for easy refilling, to suit the way the excavator is used. In addition to easily refilling water by climbing up on the side frame, water can also be refilled by placing the AdBlue® container in front of the tank.



Urea Tank Capacity: **120 L**
Refilling frequency: **Once per 11** refuellings

A large capacity tank has been used for longer refilling intervals and lower the amount of associated work. The tank needs to be refilled around once every eleven times the fuel tank is filled (may vary depending on usage conditions).

Precautions with machines installed with the SCR System

To ensure that the machine can be used safely and smoothly, use AdBlue® aqueous solution (or a urea aqueous solution that complies with ISO standards). Using a non-standard aqueous solution or diluting the solution before use may cause mechanical problems. Malfunctions arising from the use of non-standard aqueous solutions are not covered by SUMITOMO's warranty service.

- The remaining AdBlue® level can be checked during work on the monitor display in the cab. A warning is displayed on the monitor when the remaining level becomes low or there is an issue with quality.
- The engine power output will be limited if the remaining AdBlue® level falls below the minimum level or there is an issue with quality, so be sure to plan refills in advance.

Precautions when handling AdBlue®

- The SCR System is designed exclusively for the machine, and must not be used for any other purpose.
- Rinse with water any solution that comes in contact with skin.
- When storing the solution, always use sealed containers and store at room temperature in a well-ventilated location out of direct sunlight. When carrying the solution, always use the container that the solution was purchased in, or other specified container.
- The SCR System includes a heater function, however sufficient care must be taken to prevent freezing when the solution is stored in cold regions (freezing temperature: -11°C).



Example monitor warning display

Read the instruction manual for more details.

Advances Abound. Innovation Infinite.



SUMITOMO
UNIQUE DESIGN

EMS for Enhanced Maintenance of Joints

SUMITOMO's EMS (Easy Maintenance System) has been used to ensure the excavator is always at the forefront of any work site. Special bushes keep joints lubricated and prevent rattling, and help give parts like bushes and pins a longer operating life. This extends the greasing interval of joints like around the bucket and other sections, thereby reducing the amount of maintenance required.

Greasing interval for bucket: **250 hours**
Greasing interval for other sections: **1,000 hours**

* The greasing interval varies depending on operating conditions.



Attachment EMS bushing with self-lubricating capability

Bucket EMS bushing (steel) with excellent wear resistance

Higher Rigidity Boom and Arm

The boom and arm essential for operations feature a heavy-duty design and optimally shaped structure for greater strength and durability, as well as enhanced reliability of joints.

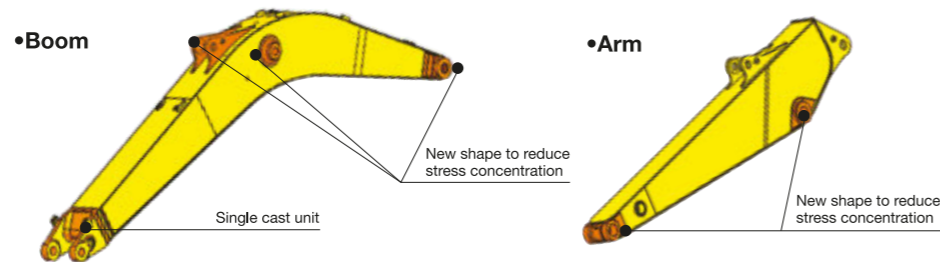

Superior Undercarriage Cleanout

A linear angled shape for the upper side frame is designed to make it easier to clean out debris from the undercarriage.

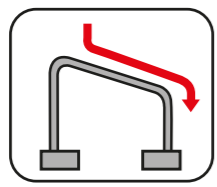

■ Upper side frame shape
Image has been simplified for illustration purposes.

Newly Designed Undercarriage for Enhanced Durability and Easier Maintenance

A new undercarriage has been developed featuring improvements to each section for increased durability, with the rollers positioned to reduce vibrations during travelling. The front idler shock absorbers have also been modified to create space beneath the track rollers for better debris cleanout.

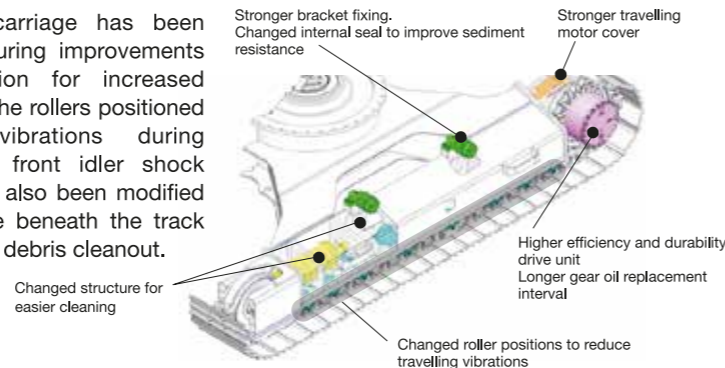

Specifications

SH210/220LC-7 Technical Data

The electronic-controlled engine of SPACE 5 α and SIH:S α with new hydraulic system includes: three working modes (SP, H and A), one-touch/automatic idling system, automatic power-boost, speed assistance system, power-swing system.

Engine

SH210/220LC-7	
Model	ISUZU VD-4HK1X
Type	Water-cooled, 4-cycle diesel, 4-cylinder in line, high pressure common rail system (electric control), turbocharger with air cooled intercooler, ATS
Rated output	119.3 kW at 1,800 min ⁻¹
Maximum torque	620 N·m at 1,600 min ⁻¹
Piston displacement	5.19 ltr (5,193 cc)
Bore and stroke	115 mm x 125 mm
Starting system	24 V electric motor starting
Alternator	24 V, 85 A
Air filter	Double element

Hydraulic pumps

Two variable displacement axial piston pumps provide power for boom/arm/bucket, swing, and travel. One gear pump for pilot controls.

SH210/220LC-7	
Maximum oil flow	2 x 211 ltr/min
Pilot pump max. oil flow	18 ltr/min

Hydraulic motors

For travel: Two variable displacement axial piston motors
For swing: One fixed displacement axial piston motor

Working circuit pressure

Boom/arm/bucket ...34.3 MPa
Boom/arm/bucket ...37.3 MPa with auto power-up
Swing circuit29.4 MPa
Travel circuit34.3 MPa

Control valve

With boom/arm holding valve
One 4-spool valve for right track travel, bucket, boom and arm acceleration
One 5-spool valve for left track travel, auxiliary, swing, boom acceleration and arm

Oil filtration

Return filter 6 microns
Pilot filter 8 microns
Suction filter 105 microns

Hydraulic cylinders

SH210/220LC-7		
Cylinder	Q'ty	Bore x rod diameter x stroke
Boom	2	120 mm x 85 mm x 1,255 mm
Arm	1	140 mm x 100 mm x 1,460 mm
Bucket	1	120 mm x 85 mm x 1,010 mm

Double-acting, bolt-up type cylinder tube-end; hardened steel bushings
Installed in cylinder tube and rods ends.

Cabin & controls

The cabin is mounted on four fluid mountings. Features include safety glass front, rear and side windows, adjustable upholstered suspension seat with headrest and armrest, cigarette lighter, pop-up skylight window, and intermittent wiper with washer. The front window slides upward for storage, and the lower front window is removable. Control levers are located in four positions with tilting control consoles. Built-in type full-colour monitor display. Membrane switch on monitor display.

Swing

Planetary reduction is powered by an axial piston motor. The internal ring gear has a grease cavity for pinion. The swing bearing is a single-row shear type ball bearing. Dual stage relief valves are used for smooth swing deceleration and stops. A mechanical disc swing brake is included.

SH210/220LC-7	
Swing speed	0~11.5 min ⁻¹
Tail swing radius	2,790 mm
Swing torque	64 kN·m

Undercarriage

An X-style carbody is integrally welded for strength and durability. The grease cylinder track adjusters have shock absorbing springs. The undercarriage has lubricated rollers and idlers.

Type of shoe: sealed link shoe

Upper rollers -
Heat treated, mounted on steel bushings with leaded tin bronze casting, sealed for lifetime lubrication.

Lower rollers -
Heat treated, mounted on steel bushings with leaded tin bronze casting, sealed for lifetime lubrication.

Track adjustment -
Idle axles adjusted with grease cylinder integral with each side frame; adjustment yoke mechanism fitted with heavy duty recoil spring.

Number of rollers and shoes on each side

	SH210-7	SH220LC-7
Upper rollers	2	2
Lower rollers	7	8
Track shoes	46	49

Travel system

Two-speed independent hydrostatic system with compact axial motors for increased performance. Hydraulic motor powered output shaft coupled to a planetary reduction unit and track sprocket. All hydraulic components mounted within the width of side frame. Travel speed can be selected by the switch panel on the monitor display. Hydraulically released disc parking brake is built into each motor.

SH210/220LC-7		
Travel speed	High	5.6 km/h
	Low	3.4 km/h
Drawbar pull	188 kN	

Lubricant & coolant capacity

SH210/220LC-7	
Hydraulic system	280 ltr
Hydraulic oil tank	162 ltr
Fuel tank	410 ltr
Cooling system	31.4 ltr
Final drive case (per side)	5.0 ltr
Swing drive case	5.0 ltr
Engine crank case	23.1 ltr
Urea water tank	120 ltr

Auxiliary hydraulic system

SH210/220LC-7			
Auxiliary piping type (option)	For Breaker	For Double (breaker & crusher) acting	For D/A + Second option line
Arm type	HD	HD	HD
Bucket linkage type	HD	HD	HD
Auxiliary hydraulic pump flow	211 ltr/min	422 ltr/min	422+60 ltr/min

Specifications

Bucket

Options and specifications may differ depending on countries and regions

Model	SH210/220LC-7		
Bucket capacity (ISO/SAE/PCSA heaped)	1.0 m ³		
Bucket type	Reinforced Horizontal-pin		
Number of teeth	6		
Width	With side cutter	1,360 mm	
	Without side cutter	1,260 mm	
Weight	811 kg		
Combination	2.40 m arm	○	
	2.94 m arm	●	

○ Suitable for materials with density up to 2,000 kg/m³ or less ● Standard bucket (Suitable for materials with density up to 1,800 kg/m³ or less)

Weight & ground pressure

Model	SH210-7			
Shoe type	Shoe width	Overall width	Operating weight	Ground pressure
Triple grouser shoe	600 mm	2,800 mm	22,200 kg	50 kPa

Model	SH220LC-7			
Shoe type	Shoe width	Overall width	Operating weight	Ground pressure
Triple grouser shoe	600 mm	2,990 mm	22,500 kg	47 kPa

Digging force

Model	SH210/220LC-7			
Arm length	2.40 m		2.94 m	
Bucket digging force (with auto power up)	ISO 6015	141 kN <154 kN>	141 kN <154 kN>	
Arm digging force (with auto power up)	ISO 6015	123 kN <134 kN>	103 kN <112 kN>	

Lifting Capacity

- Notes: 1. Ratings are based on ISO 10567
 2. Lifting capacity does not exceed 75% of tipping load with the machine on firm, level ground or 87% full hydraulic capacity.
 3. The load point is arm top.
 4. *Indicates load limited by hydraulic capacity.
 5. 0 m = Ground.

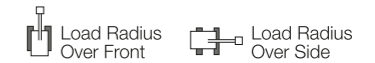
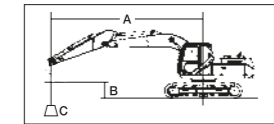

Unit: kg

SH210-7

SHOE : 600 (mm) G
 MAXIMUM REACH = 8.45 (m)
 ARM LENGTH = 2.94 (m)
 BOOM : 5.70 (m)

Arm Top Height	Max. Radius		Radius of Load										Min. Radius									
	○	□	○	□	○	□	○	□	○	□	○	□	○	□	○	□						
7 m	(kg) 3 830*	(m) 6.65	(kg) 3 830*	(m) 6.65												(kg) 4 820*	(m) 5.80	(kg) 4 820*	(m) 5.80			
6 m	3 670*	7.33	3 460	7.33												4 900*	5.69	4 900*	5.69			
5 m	3 610*	7.82	3 060	7.82												5 410*	5.18	5 410*	5.18			
4 m	3 620*	8.16	2 810	8.16	4 480	2 910	5 310*	3 640	5 670*	4 650	6 270*	6 150	7 300*	7 300*		7 700*	3.73	7 700*	3.73			
3 m	3 690*	8.37	2 650	8.37	4 410	2 860	5 450	3 530	6 250*	4 460	7 220*	5 830	8 980*	8 090		12 180*	3.06	12 130	3.06			
2 m	3 820*	8.45	2 560	8.45	4 340	2 790	5 320	3 410	6 720	4 270	8 160*	5 530	10 550*	7 560		7 350*	3.28	7 350*	3.28			
1 m	3 970	8.41	2 530	8.41	4 280	2 730	5 210	3 310	6 540	4 110	8 620	5 290	11 630*	7 200		5 650*	3.17	5 650*	3.17			
0 m	4 050	8.25	2 570	8.25	4 230	2 690	5 120	3 230	6 410	4 000	8 440	5 130	12 160*	7 020	6 530*	6 530*		4 960*	2.71	4 960*	2.71	
-1 m	4 250	7.96	2 690	7.96			5 070	3 190	6 330	3 930	8 350	5 050	12 100	6 960	9 490*	9 490*	5 950*	5 950*	5 200*	1.56	5 200*	1.56
-2 m	4 600	7.53	2 910	7.53			5 070	3 190	6 310	3 910	8 330	5 030	11 970*	6 970	13 070*	11 150	9 310*	9 310*	8 080*	1.15	8 080*	1.15
-3 m	5 220	6.92	3 300	6.92					6 360	3 950	8 380	5 080	11 310*	7 050	14 430*	11 310	12 980*	12 980*	11 310*	1.24	11 310*	1.24
-4 m	6 310*	6.09	4 010	6.09					6 480*	4 080	8 190*	5 200	10 140*	7 210	12 760*	11 550	16 870*	16 870*	16 460*	1.72	16 460*	1.72
-5 m	6 240*	4.92	5 580	4.92									8 060*	7 480					10 050*	3.03	10 050*	3.03

SH210-7

SHOE : 600 (mm) G
 MAXIMUM REACH = 7.97 (m)
 ARM LENGTH = 2.40 (m)
 BOOM : 5.70 (m)

Arm Top Height	Max. Radius		Radius of Load										Min. Radius							
	○	□	○	□	○	□	○	□	○	□	○	□	○	□	○	□				
7 m	(kg) 5 670*	(m) 6.03	(kg) 4 820	(m) 6.03												(kg) 5 490*	(m) 5.26	(kg) 5 490*	(m) 5.26	
6 m	5 510*	6.77	3 960	6.77												5 620*	5.13	5 620*	5.13	
5 m	5 260	7.30	3 460	7.30	5 590*	3 720	5 770*	4 780	6 170*	6 170*						6 520*	4.45	6 520*	4.45	
4 m	4 810	7.66	3 150	7.66	5 570	3 660	6 210*	4 630	6 970*	6 080	8 350*	8 350*				10 140*	3.31	10 140*	3.31	
3 m	4 550	7.88	2 960	7.88	5 470	3 560	6 750*	4 460	7 900*	5 790	10 050*	7 930				10 760*	3.79	8 540	3.79	
2 m	4 420	7.97	2 860	7.97	5 360	3 460	6 740	4 300	8 760*	5 520	11 470*	7 480				11 590*	3.97	7 550	3.97	
1 m	4 410	7.93	2 840	7.93	5 270	3 380	6 590	4 170	8 650	5 330	11 770*	7 230				9 950*	3.89	7 540	3.89	
0 m	4 520	7.76	2 900	7.76	5 210	3 320	6 490	4 080	8 520	5 220	12 290	7 140				8 350*	3.52	8 350*	3.52	
-1 m	4 770	7.45	3 060	7.45	5 180	3 300	6 440	4 040	8 470	5 170	12 270*	7 130	9 010*	9 010*		7 650*	2.75	7 650*	2.75	
-2 m	5 250	6.98	3 350	6.98			6 460	4 050	8 490	5 190	11 770*	7 180	14 340*	11 510	10 000*	10 000*	9 330*	1.69	9 330*	1.69
-3 m	6 100	6.32	3 880	6.32			6 540	4 130	8 580	5 260	10 860*	7 290	13 480*	11 670	15 320*	15 320*	14 650*	1.80	14 650*	1.80
-4 m	6 630*	5.39	4 930	5.39					7 440*	5 440	9 310*	7 480	11 470*	11 470*		12 970*	2.43	12 970*	2.43	

Lifting Capacity

- Notes: 1. Ratings are based on ISO 10567
 2. Lifting capacity does not exceed 75% of tipping load with the machine on firm, level ground or 87% full hydraulic capacity.
 3. The load point is arm top.
 4. *Indicates load limited by hydraulic capacity.
 5. 0 m = Ground.

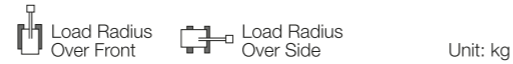
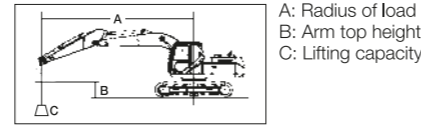

SH220LC-7

SHOE : 600 (mm) G
 MAXIMUM REACH = 8,45 (m)
 ARM LENGTH = 2.94 (m)
 BOOM : 5.70 (m)

Arm Top Height	Radius of Load																			
	Max. Radius		8 m		7 m		6 m		5 m		4 m		3 m		2 m		Min. Radius			
	(kg)	(m)	(kg)	(m)													(kg)	(m)	(kg)	(m)
7 m	3 830*	6.65	3 830*	6.65				4 860*	4 860*								4 820*	5.80	4 820*	5.80
6 m	3 670*	7.33	3 670*	7.33			4 960*	4 150	4 900*	4 900*							4 900*	5.69	4 900*	5.69
5 m	3 610*	7.82	3 380	7.82			5 050*	4 110	5 200*	5 200*							5 410*	5.18	5 410*	5.18
4 m	3 620*	8.16	3 110	8.16	4 610*	3 220	5 310*	4 020	5 670*	5 120	6 270*	6 270*	7 300*	7 300*			7 700*	3.73	7 700*	3.73
3 m	3 690*	8.37	2 930	8.37	4 950	3 160	5 660*	3 900	6 250*	4 930	7 220*	6 460	8 980*	8 980*			12 180*	3.06	12 180*	3.06
2 m	3 820*	8.45	2 840	8.45	4 880	3 100	5 990	3 790	6 840*	4 740	8 160*	6 150	10 550*	8 480			7 350*	3.28	7 350*	3.28
1 m	4 040*	8.41	2 820	8.41	4 810	3 030	5 870	3 680	7 370*	4 580	8 940*	5 910	11 630*	8 120			5 650*	3.17	5 650*	3.17
0 m	4 340*	8.25	2 870	8.25	4 760	2 990	5 780	3 600	7 270	4 460	9 440*	5 740	12 160*	7 930	6 530*	6 530*	4 960*	2.71	4 960*	2.71
-1 m	4 780	7.96	3 000	7.96			5 730	3 560	7 200	4 390	9 570	5 660	12 240*	7 860	9 490*	9 490*	5 950*	1.56	5 200*	1.56
-2 m	5 190	7.53	3 240	7.53			5 730	3 550	7 180	4 370	9 560	5 640	11 970*	7 880	13 070*	12 810	9 310*	1.15	8 080*	1.15
-3 m	5 900	6.92	3 670	6.92					7 220	4 410	9 130*	5 690	11 310*	7 960	14 430*	12 970	12 980*	1.24	11 310*	1.24
-4 m	6 310*	6.09	4 460	6.09					6 480*	4 540	8 190*	5 810	10 140*	8 120	12 760*	12 760*	16 870*	1.72	16 460*	1.72
-5 m	6 240*	4.92	6 220	4.92											8 060*	8 060*			10 050*	3.03

SH220LC-7

SHOE : 600 (mm) G
 MAXIMUM REACH = 7,97 (m)
 ARM LENGTH = 2.40 (m)
 BOOM : 5.70 (m)

Arm Top Height	Radius of Load																			
	Max. Radius		7 m		6 m		5 m		4 m		3 m		2 m		Min. Radius					
	(kg)	(m)	(kg)	(m)												(kg)	(m)	(kg)	(m)	
7 m	5 670*	6.03	5 290	6.03			5 660*	5 330								5 490*	5.26	5 490*	5.26	
6 m	5 510*	6.77	4 350	6.77			5 520*	5 350								5 620*	5.13	5 620*	5.13	
5 m	5 410*	7.30	3 810	7.30	5 590*	4 100	5 770*	5 250	6 170*	6 170*						6 520*	4.45	6 520*	4.45	
4 m	5 390	7.66	3 480	7.66	5 780*	4 030	6 210*	5 100	6 970*	6 720	8 350*	8 350*				10 140*	3.31	10 140*	3.31	
3 m	5 100	7.88	3 270	7.88	6 080*	3 930	6 750*	4 930	7 900*	6 410	10 050*	8 860				10 760*	3.79	9 580	3.79	
2 m	4 960	7.97	3 170	7.97	6 030	3 830	7 290*	4 770	8 760*	6 140	11 470*	8 390				11 590*	3.97	8 480	3.97	
1 m	4 950	7.93	3 150	7.93	5 930	3 750	7 460	4 630	9 410*	5 950	11 770*	8 140				9 950*	3.89	8 500	3.89	
0 m	5 080	7.76	3 220	7.76	5 870	3 690	7 350	4 540	9 750	5 830	12 440*	8 050				8 350*	3.52	8 350*	3.52	
-1 m	5 370	7.45	3 400	7.45	5 840	3 670	7 310	4 500	9 700	5 780	12 270*	8 040	9 010*	9 010*		7 650*	2.75	7 650*	2.75	
-2 m	5 910	6.98	3 720	6.98			7 320	4 510	9 540*	5 800	11 770*	8 090	14 340*	13 180	10 000*	10 000*	9 330*	1.69	9 330*	1.69
-3 m	6 640*	6.32	4 310	6.32			7 200*	4 590	8 860*	5 880	10 860*	8 200	13 480*	13 350	15 320*	15 320*	14 650*	1.80	14 650*	1.80
-4 m	6 630*	5.39	5 480	5.39					7 440*	6 050	9 310*	8 400	11 470*	11 470*			12 970*	2.43	12 970*	2.43

Principle Specifications

	SH210-7 STD Specifications	SH220LC-7 STD Specifications
Base		
Boom length		5.70 m
Arm length		2.94 m
Bucket capacity (ISO heaped)	1.0 m ³	1.0 m ³
Std. operating weight	22,200 kg	22,500 kg
Engine		ISUZU 4HK1X
Rated output		119.3 kW/1,800 min ⁻¹
Displacement		5.19 ltr
Hydraulic System		2 variable displacement axial piston pumps with regulating system
Main pump		34.3 MPa
Max. pressure		37.3 MPa
(with auto power boost)		
Travel motor		Variable displacement axial piston motor
Parking brake type		Mechanical disc brake
Swing motor		Fixed displacement axial piston motor
Performance		
Travel speed (high/low)		5.6/3.4 km/h
Drawbar pull		188 kN
Gradeability		70% <35°>
Ground pressure	50 kPa	47 kPa
Swing speed		11.5 min ⁻¹
Bucket digging force		141 kN
/with power boost		154 kN
Arm digging force		103 kN
/with power boost		112 kN
Others		
Fuel tank		410 ltr
Hydraulic fluid tank		162 ltr
Urea water tank		120 ltr

Working Range

	SH210/220LC-7	
Arm length	2.40 m	2.94 m
Boom length	5.70 m	
A Max. digging radius	9,420 mm	9,900 mm
B Max. digging depth	6,110 mm	6,640 mm
C Max. digging height	9,400 mm	9,610 mm
D Max. dumping height	6,580 mm	6,810 mm
E Max. vertical wall cut depth	5,510 mm	5,950 mm
F Min. front swing radius	3,620 mm	3,640 mm
G Rear end swing radius	2,790 mm	

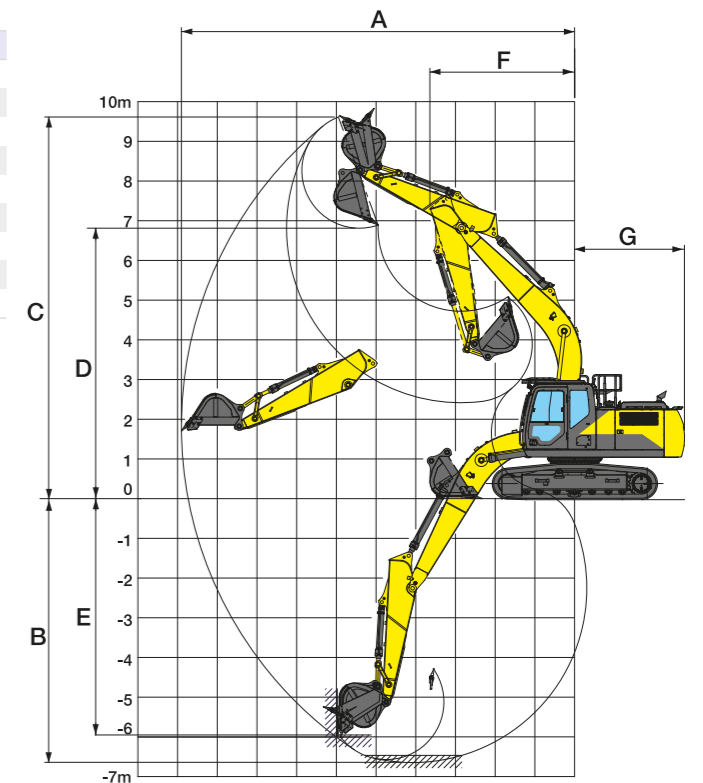

Standard Equipment

[Hydraulic system]

- SIH:Si hydraulic system
- Operation mode (SP, H and A mode)
- Automatic 2-speed travel
- Automatic power boost
- Boom/arm holding valve
- Arm/boom/bucket reactivation circuit
- Automatic swing parking system
- Auxiliary valve
- High-performance return filter

[Cabin/interior equipment]

- Shock-less cab suspension with 4-point fluid mounts
- New full-colour LCD monitor
- Tilting console
- Fresh-air intake pressurised full-automatic air conditioner
- Defroster
- Hot & cool box
- High water-repellent seat
- Seat suspension
- Armrest & headrest
- Windscreen wiper (with intermittent operation function)
- Cup holder
- Magazine rack
- Accessory case
- Floor mat
- Ashtray & cigarette lighter
- Cab light (Auto-OFF function)
- Coat hook
- Operation lever with one-touch wiper switch
- Polycarbonate roof top window with sunshade
- 12V power (DC-DC converter)

[Safety equipment]

- ROPS cab (FOPS level 1)
- Head guard (OPG Level 2)
- Rear/right side camera
- Rearview mirror (left/right)
- Emergency escape tool
- Retracting seat belt
- Gate lock lever (engine neutral start)
- Travel alarm
- Anti-theft alarm system
- Engine room firewall
- Fan guard
- Engine emergency stop switch

[Others]

- Auto/one-touch idling
- Auto idle shutdown system
- EMS
- Long-life hydraulic oil
- Five lights (chassis, left/right of boom, cab)
- Fuel filter (with water separator and clogging sensor)
- Fuel pre-filter (with water separator)
- Double-element air cleaner
- Grease-enclosed track link
- Large tool box
- A set of tools
- Pre-air cleaner

Accessories (option)

■ Cab-top lights (LED)



■ Camera lights (LED) (top: side, bottom: rear)



■ Rain deflector



■ Sun visor



■ Front mesh guard (full)



■ Front guard (OPG level 1 or 2)



■ Refuel pump

■ Hose burst check valve (HBCV) for boom/arm cylinders

Accessories and specifications may differ depending on countries and regions.

Dimensions

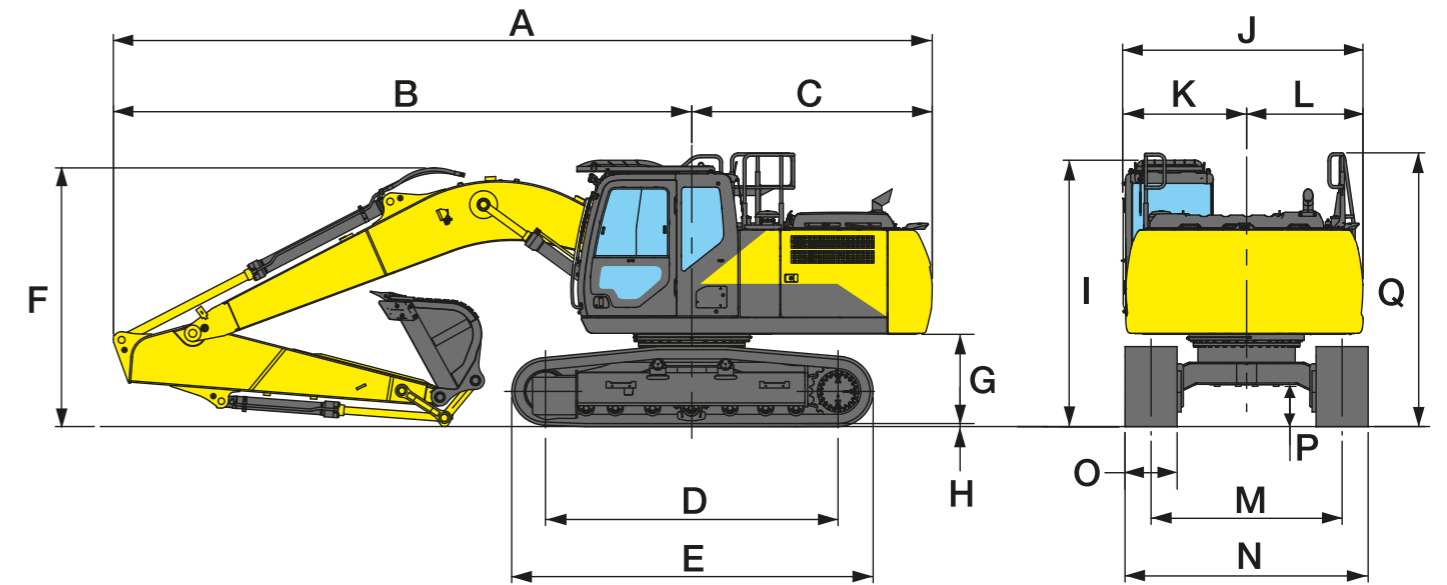

Model	SH210/220LC-7	
Arm length	2.40 m	2.94 m
A Overall length	9,510 mm	9,430 mm
B Length from centre of machine (to arm top)	6,740 mm	6,660 mm
C Length from centre of machine (to rear end)		2,770 mm
D Centre to centre of wheels		3,370 (3,660) mm
E Overall track length		4,180 (4,470) mm
F Overall height	3,170 mm	2,980 mm
G Clearance height under upper structure		1,040 mm
H Shoe lug height		26 mm
I Cab height		3,100 mm
J Upper structure overall width		2,770 mm
K Width from centre of machine (left side)		1,430 mm
L Width from centre of machine (right side)		1,340 mm
M Track gauge		2,200 (2,390) mm
N Overall width		2,800 (2,990) mm
O Std. shoe width		600 mm
P Minimum ground clearance		440 mm
Q Handrail height		3,150 mm

Figure in (): LC type