

SUMITOMO

SH80BS-7 Hydraulic Excavator

 **SUMITOMO CONSTRUCTION MACHINERY CO., LTD.**

731-1 Naganumahara-cho, Inage-ku, Chiba, 263-0001 Japan
For further information please contact: Phone : +81-43-420-1829 Facsimile : +81-43-420-1907

We are constantly improving our products and therefore reserve the right to change designs and specifications without notice.
Illustrations may include optional equipment and accessories and may not include all standard equipment.



SUMITOMO EXCAVATORS

SH80BS-7

- Engine Rated Power (Net): 50.7 kW
- Operating Weight:
 - SH80BS-7 8,720 kg
- Bucket Capacity (ISO Heaped): 0.28~0.34 m³

HYDRAULIC EXCAVATOR FOR REAL PERFORMANCE

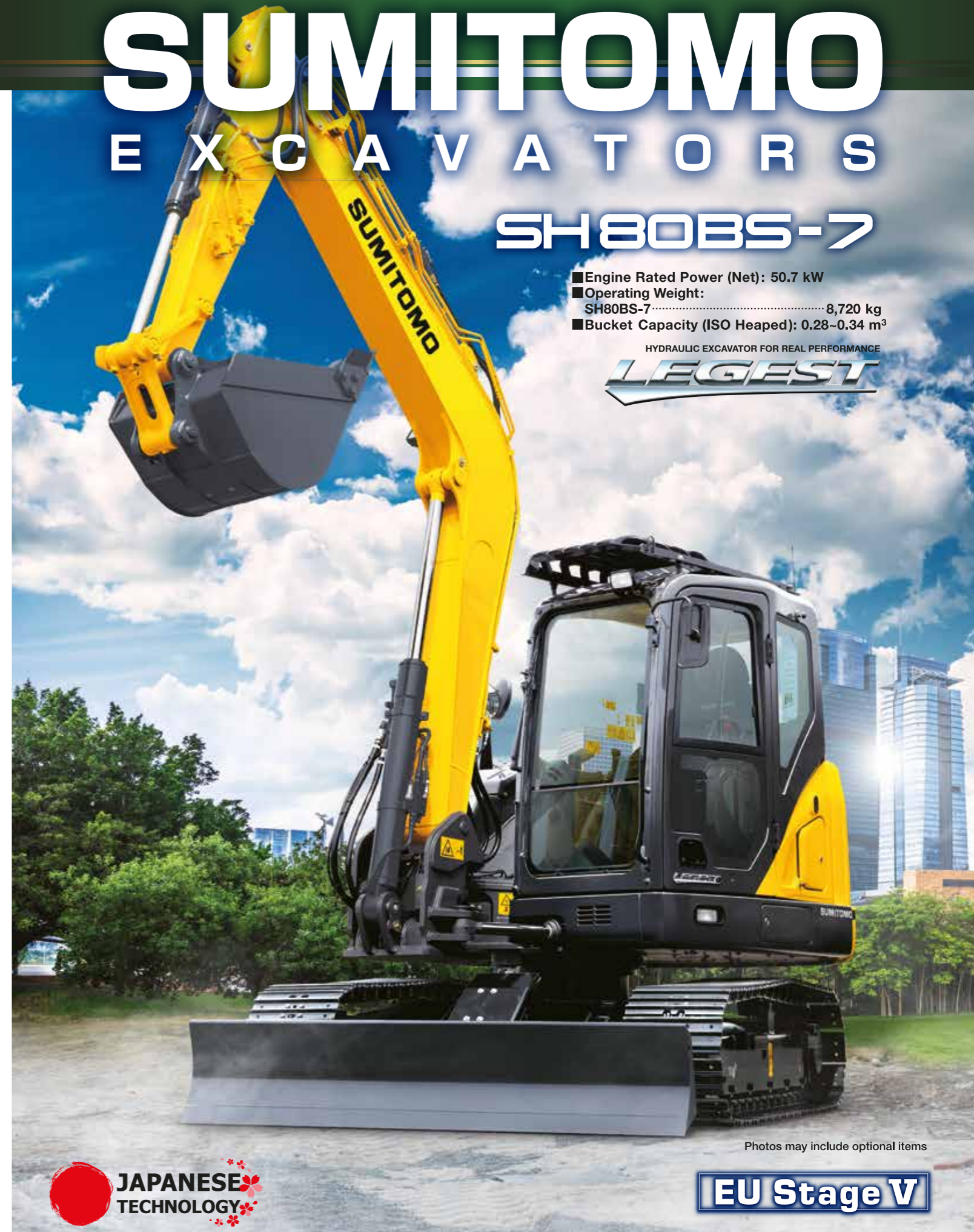

Photos may include optional items



EU Stage V

Advances Abound. Innovation Infinite.

Exhilarating mobility with superior safety, comfort and efficiency.
All-new compact excavator
delivers tomorrow's capabilities today.

Designed with sophisticated agility to deliver the best performance on future worksites. Sumitomo's LEGEST has been continuously refined to exceed itself in the quest for even greater control precision. Even better operator comfort and socially conscious design, coupled with eco-friendly efficiency and the ultimate in smooth, adaptable operations. Enhanced capabilities that will captivate any operator seeking to progress to a new stage.

LEGEST

Advanced Energy Efficiency and Eco-friendly Operation 04-07

- Clean and Fuel-efficient Engine "SPACE 5 α"
- Innovative Hydraulic System "SIH:S α"
- SUMITOMO Technology for Fuel Efficiency

Unparalleled Performance 08-09

Advanced Operator Comfort 10-11

- New Monitor
- New Air Suspension Seat

Sophisticated Safety Features 12-13

- Rear and Right Side Camera

Superior Ease-of-maintenance and Durability 14-16

- Ground Level Access
- EMS

Specifications 17-23

Advanced Energy Efficiency and Eco-friendly Operation

The combination of the advanced clean engine "SPACE 5 α" and SUMITOMO's proprietary hydraulic system "SIH:S α" achieves much higher operating efficiency and superior fuel economy. These features also mean the excavator is even easier on the environment and worksites.

Faster Operations and Excellent Fuel Economy!

Clean engine **SPACE 5 α** × Innovative hydraulic system **SIH:S α** = **7%*** less fuel consumption

* Comparison of fuel consumption with same workload (SH80BS-7 SP mode compared against SH80BS-6A SP mode)
The level of reduction may be less than shown above depending on actual job type.

Meets EU Stage V standards

The clean engine "SPACE 5 α" achieves significant reductions in exhaust gas emissions, meeting European Stage V non-road emission standards (EU Stage V), deemed the toughest emissions standards in the world. The SH80BS-7 series excavator has been designed to be even more environmentally friendly.

PM: 40% reduction

(compared to SH80BS-6A)

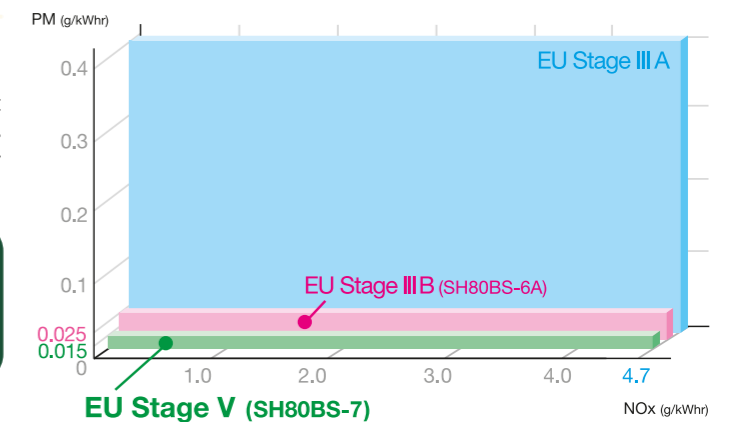

Fuel-efficient clean engine "SPACE 5 α"

The clean engine "SPACE 5 α" achieves significant reductions in exhaust gas emissions, meeting European Stage V non-road emission standards (EU Stage V), deemed the toughest emissions standards in the world. The SH80BS-7 series excavator has been designed to be even more environmentally friendly.

New high-output engine

The SH80BS-7 is powered by a new high-output Yanmar engine that delivers excellent performance with a superior environmentally conscious design. With a 1.1 L increase in displacement, the rated power output is approximately 27% higher than previous models while retaining low fuel consumption. This provides greater headroom for jobs needing a high level of power, making operations all the more smoother.

ATS for eliminating PM emissions

Features an exhaust ATS (After Treatment System) that collects and burns PM contained within the exhaust gas. Filter cleaning control automatically burns any PM as it builds up.

How ATS works

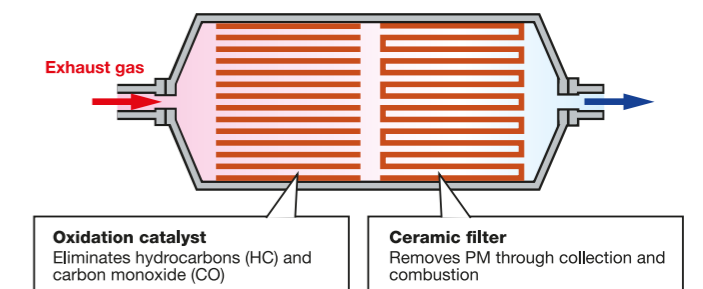

Advanced Energy Efficiency and Eco-friendly Operation

Innovative Hydraulic System "SIH:S α"

An innovative hydraulic system has been used, with pumps perfectly matched to the engine for much faster operating speed, real digging power and predictable control exactly as the operator intends. This makes work more even more efficient and significantly lower fuel consumption.

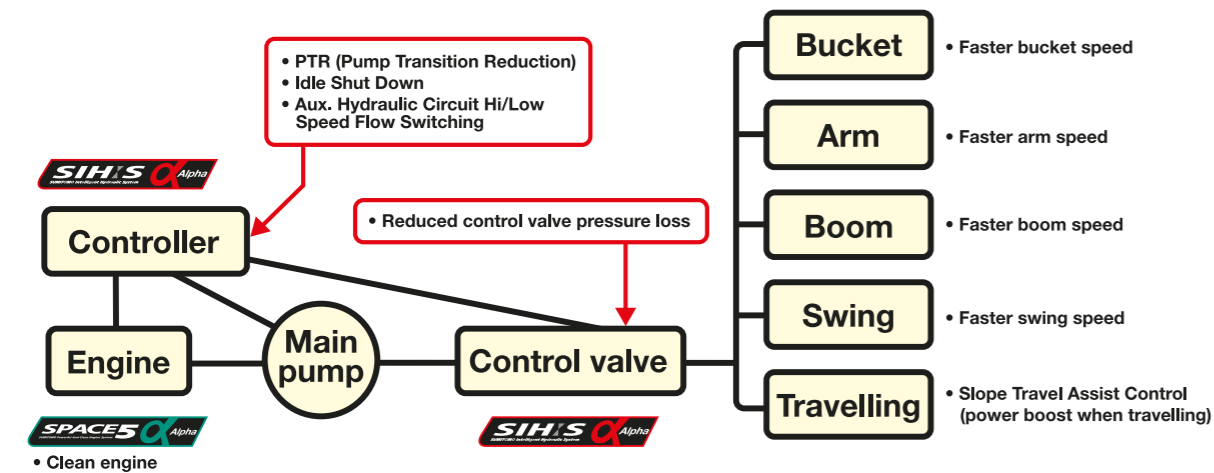

Three Working Modes for Economic Operation or Work Efficiency



Three working modes are available: SP (Super Power) for faster operations, H (Heavy) for heavy duty applications, and A (Auto) for fuel efficiency across a wide range of operations. Six levels are shown for A mode, making it easier to select the right mode for any jobsite.



Integrated Throttle Mode Selector

The throttle mode can be selected by simply turning the knob, so anyone can easily choose the optimum working mode.

SUMITOMO Technology for Fuel Efficiency

• PTR (Pump Transition Reduction)

Decreases main pump loads to reduce fuel consumption.

• Idle Shut Down & Auto Idle

Detects when the machine is not in operation, and automatically stops the engine from idling. Also equipped with Auto Idle, which automatically switches the engine to idle when the operation levers are in neutral position.



Unprecedented Operating Performance

The Innovative Hydraulic System “SIH:S α” provides a stunning new level of performance on job sites. This ensures optimum engine and pump operation for precision control across the entire operating range. The excavator responds exactly as the operator is expecting, with predictable speed, digging power and movement streamlining work on any job site.

Designed for Superior Working Speed

The hydraulic control system has been enhanced and optimised to deliver the equivalent cycle time as previous models renowned for their speedy capabilities, resulting in even greater work site efficiency.

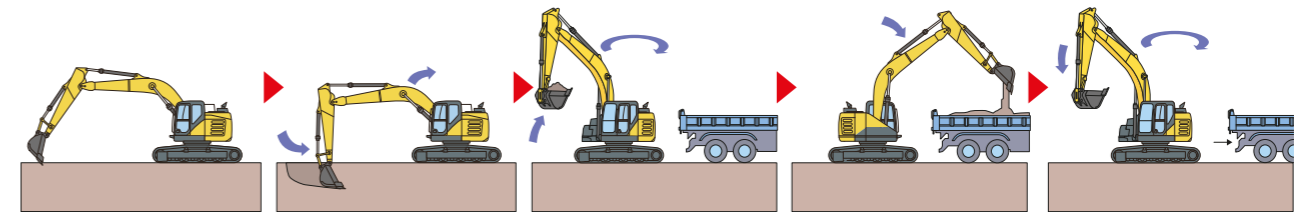

Superior Workload and Productivity

The hydraulic control system has been optimised for maximum productivity. The system prioritises controls when work calls for careful handling, thus achieving both high volume and delicate operations, resulting in even greater work site efficiency.

Increased Digging Power

Pump power is reduced for low-load operations, and boosted for heavy-duty digging work. The faster response means more stress-free operations.

Mobility with Swing Boom Suited to a Diverse Range of Jobs

Intelligently designed for narrow urban spaces or job sites with many obstructions. Versatility and capability for working in confined areas, with a swing boom that can be positioned anywhere within a 125-degree arc.

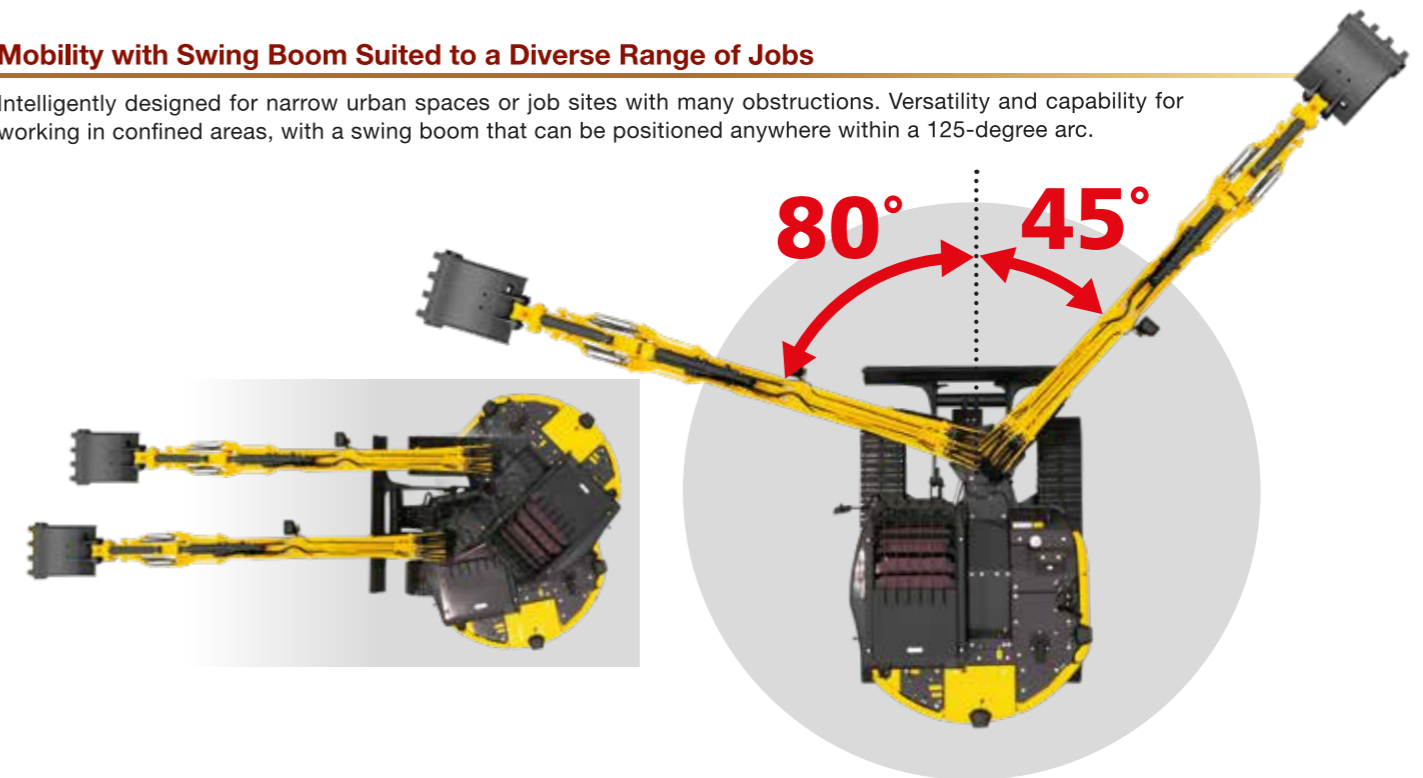



Advanced Operator Comfort

A comfortable cabin has been designed to reduce operator fatigue, with the aim of relieving stress during work and ensuring greater relaxation during downtime. With features such as a spacious cabin interior, new high-definition monitor with smartphone-like usability, new air suspension seat, and unbelievably quiet operation, the cabin is both comfortable and intuitive to ensure a greater level of safety.

New Monitor—Even More Intuitive and User-friendly

A wide range of excavator operating and maintenance information, warnings and other data are displayed as text messages. Providing a way to view accurate and easy-to-understand information helps to boost operating efficiency and safety.

Illustrations of new monitor displays



Indicators

- 1 Working modes
- 2 Icons
- 3 Warning messages
- 4 Engine coolant temperature
- 5 Fuel level
- 6 ATS warning
- 7 Camera view (rear camera)
- 8 Camera view (right side camera)

Switch Panel

- A Travel speed button
- B ATS purge
- C Aux. hydraulic settings
- D Window wiper
- E Window washer
- F Work lights
- G Auto idle/Idle stop
- H Display modes
- I Hour meter toggle (trip/total)

Spacious, Class-leading Cabin

Just like previous models, the cabin has been designed with features that are top of its class, all of which help to ensure a comfortable and stress-free space for the operator. Superior sound insulation throughout the cabin translates to top-class levels of silence within.

Automatic Air-conditioner

Fully automatic climate control maintains a comfortable temperature within the cabin. The optimal ducting layout and airtight cabin also help to boost air-conditioning efficiency.



New Air Suspension Seat

The operator's seat features air suspension as standard for outstanding ride comfort. A new high-performance reclining seat with higher seatback has been used to ensure premium comfort. A multitude of seat adjustments and ample seat cushion width all help to significantly lower operator fatigue. The high water-repellent seat material is also easier to keep clean.



Seat air suspension

Premium Comfort with Seat Heater (OPTION)

A seat heater function is now available as an optional extra for even greater comfort in cold seasons or working early mornings. A convenient seat tilting function has also been added that allows the seat cushion to be tilted forward or back to suit the operator's body type or particular job—now anyone can achieve the optimum seating posture for more comfortable control.



Seat heater switch

Equipment for Comfort and Safety



Magazine rack



Cup holder



Under-cab storage space



Anti-theft system



Emergency stop switch



Sophisticated Safety Features

The cabin provides excellent driving visibility, and features a high-strength design to better protect the operator. Every aspect has been designed for day-to-day safety, including excellent access in and out of the cabin, and steps and handrails to make inspections and maintenance easier. The use of a new rear camera and LED cabin top light also helps to ensure operations remain safe.

Safe ROPS-compliant Cabin

A high-strength cabin design means operators are even better protected.

ROPS: Roll-Over Protective Structure

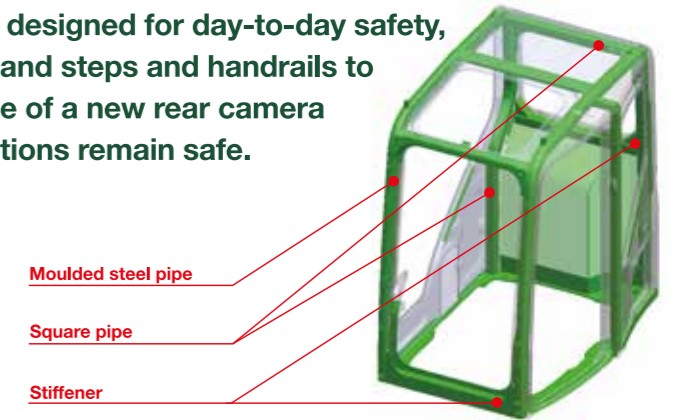

Wide View for Excellent Site Safety

In addition to the front of the excavator, the cabin design gives the operator a wide, unrestricted view to check upper and lower areas. Direct visibility for the operator means work can be performed safer.

Rear and Right Side Cameras

Two cameras are installed as standard—rear view and on the right side—so the operator can check for safety behind the excavator. Optimally positioned mirrors and the use of cameras ensure that mirror visibility meets ISO standards, thus making it easier for the operator to check for safety in any desired direction.



Monitor videos



Rear camera



Right side camera

Superb Access

The wide door opening and large handrails provide excellent access up to and down from the cabin. The spacious footwell also makes it easier to get in and out.



Large handrail and spacious footwell

LED Cabin Top Light (OPTION)

A long-life LED cabin top light is now available as an optional extra. Super bright and with a high-visibility colour, the light enhances safety during night-time operations.



LED cabin top light

Easy Access to the Upper Structure

ISO compliant hand grip and lower step allow easy access to the upper structure. Shape of the right-hand corner cover has been optimised for better visibility from the cabin.



Hand grip

Lower step

ISO-compliant hand grip and lower step



Superior Ease-of-maintenance and Durability

Easy maintenance and durability are the key to excavators that are called upon for ongoing work at job sites. With enhanced durability at every corner and proprietary EMS, outstanding reliability is standard with SUMITOMO excavators—they are designed to be easy to operate and maintain for customers, including features like ground level access.

Ground Level Access for Easy Inspections and Maintenance

Components requiring inspection are all in a central location, meaning inspections and refilling can be performed without having to climb up onto the excavator.

•Increased Cooling Performance

The use of a larger radiator and oil cooler help to increase cooling performance and reliability. It is also easier to clean the dust-proof net.

•Designed for Easy Filter Replacement

The pre-fuel filter is designed to reduce issues due to a blocked fuel filter, and the easily accessible location of the fuel and oil filters ensure smooth inspection and replacement work.

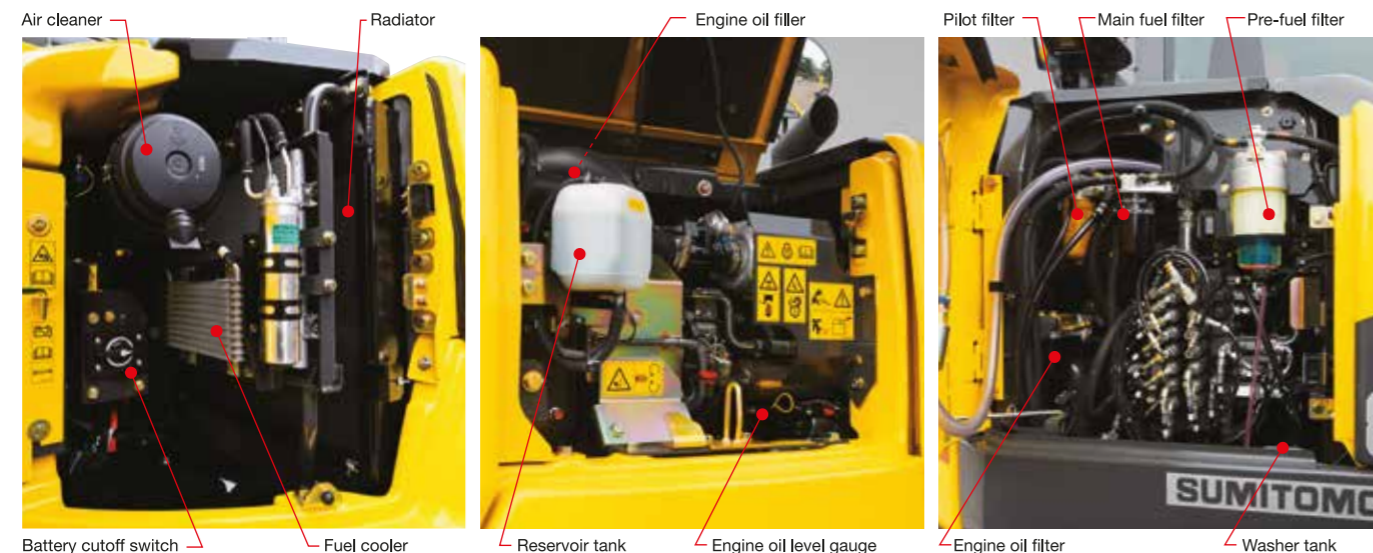

Air cleaner Radiator Engine oil filler Pilot filter Main fuel filter Pre-fuel filter Battery cutoff switch Fuel cooler Reservoir tank Engine oil level gauge Engine oil filter Washer tank

Dust-proof Net for Enhanced Ground Level Access

A dust-proof net mounted on the front of cooling package reduces the amount of dust adhesion, leading to a higher level of reliability. Ground level access means the dust-proof net can be quickly removed for easy cleaning.

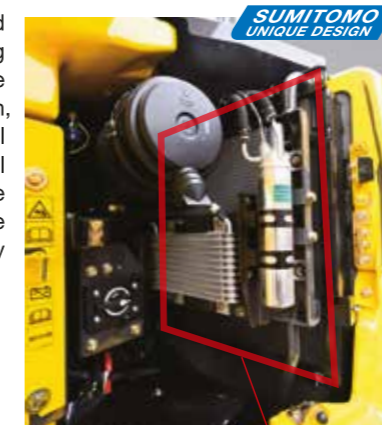

Dust-proof net

High-Performance Return Filter

A long hydraulic oil change interval of 5,000 hours, and the use of a high-performance return filter ensures superior ease-of-maintenance.



Hydraulic oil change: **5,000 hours**
Filter life: **2,000 hours**

* The oil and filter change intervals vary depending on operating conditions.

Battery Cutoff Switch

A battery switch is mounted inside the inspection cover, ensuring safe operations during maintenance procedures.



Other Maintenance Features



Central fuse box located behind seat Easy-access AC filter Washable cab floor and floor mats

Advances Abound. Innovation Infinite.



EMS for Enhanced Maintenance of Joints

SUMITOMO's EMS (Easy Maintenance System) has been used to ensure the excavator is always at the forefront of any work site. Special bushes keep joints lubricated and prevent rattling, and help give parts like bushes and pins a longer operating life. This extends the greasing interval of joints like around the bucket and other sections, thereby reducing the amount of maintenance required.

Greasing interval for bucket: 250 hours
Greasing interval for other sections: 1,000 hours

* The greasing interval varies depending on operating conditions.



Attachment EMS bushing with self-lubricating capability

Bucket EMS bushing (steel) with excellent wear resistance

High Rigidity Attachments

The boom and arm are essential for operations, so high-load sections feature optimised shapes and structures to ensure ample strength and durability. High strength castings have also been used for the boom top for greater reliability.

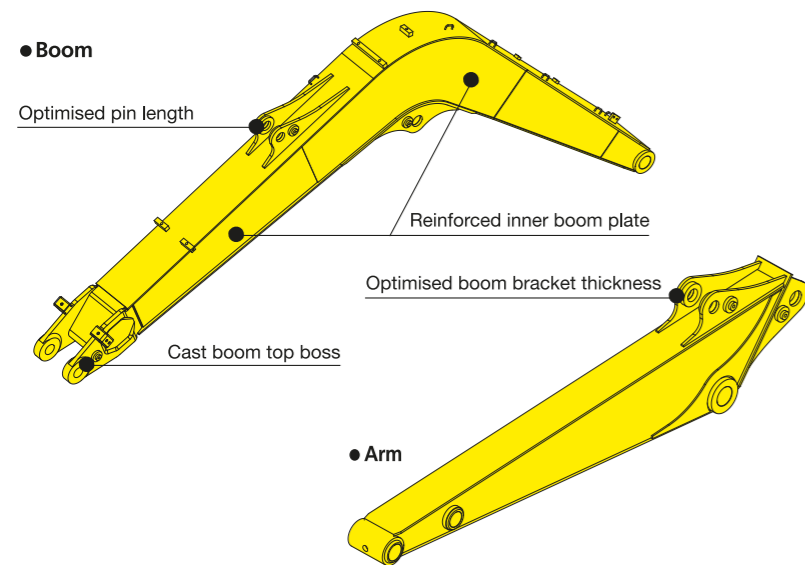

Superior Undercarriage Cleanout

A linear angled shape for the upper side frame is designed to make it easier to clean out debris from the undercarriage.

■ Upper side frame shape
Image has been simplified for illustration purposes.

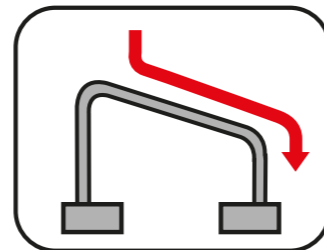

Specifications

SH80BS-7 Technical Data

The electronic-controlled engine of SPACE 5 α and SIH:S α with New Hydraulic System Includes: three working modes (SP, H and A), and one-touch/automatic idling system.

Engine

| SH80BS-7 | |
|---------------------|--|
| Model | YANMAR 4TNV98CT |
| Type | Water-cooled, 4-cycle diesel, 4-cylinder in line, high pressure common rail system (electric control), turbocharger, ATS |
| Rated output | 50.7 kW at 2,000 min ⁻¹ |
| Maximum torque | 279 N·m at 1,300 min ⁻¹ |
| Piston displacement | 3,318 ltr (3,318 cc) |
| Bore and stroke | 98 mm x 110 mm |
| Starting system | 24 V electric motor starting |
| Alternator | 24 V, 60 A |
| Air filter | Double element |

Hydraulic pumps

Two variable displacement axial piston pumps provide power for boom/arm/bucket, swing, and travel. One gear pump for pilot controls.

| SH80BS-7 | |
|--------------------------|----------------|
| Maximum oil flow | 2 x 74 ltr/min |
| Pilot pump max. oil flow | 18 ltr/min |

Hydraulic motors

For travel: Two variable displacement axial piston motors
For swing: One fixed displacement axial piston motor

Working circuit pressure

Boom/arm/bucket 29.4 MPa
Swing circuit 24.0 MPa
Travel circuit 29.4 MPa

Control valve

With boom/arm holding valve
One 5-spool valve for right track travel, bucket, boom, arm acceleration and boom swing
One 5-spool valve for left track travel, auxiliary, swing, boom acceleration and arm
One 1-spool valve for blade

Oil filtration

Return filter 6 microns
Pilot filter 8 microns
Suction filter 105 microns

Hydraulic cylinders

| SH80BS-7 | | |
|------------|------|------------------------------|
| Cylinder | Q'ty | Bore x rod diameter x stroke |
| Boom | 1 | 115 mm x 75 mm x 850 mm |
| Arm | 1 | 100 mm x 65 mm x 755 mm |
| Bucket | 1 | 85 mm x 55 mm x 665 mm |
| Boom Swing | 1 | 95 mm x 55 mm x 675 mm |
| Blade | 1 | 110 mm x 70 mm x 180 mm |

Double-acting, bolt-up type cylinder tube-end; hardened steel bushings installed in cylinder tube and rods ends.

Cabin & controls

The cabin is mounted on four fluid mountings. Features include safety glass front, rear and side windows, adjustable upholstered suspension seat with headrest and armrest, cigarette lighter, pop-up skylight window, and intermittent wiper with washer. The front window slides upward for storage, and the lower front window is removable. Built-in type full-colour monitor display. Membrane switch on monitor display.

Swing

Planetary reduction is powered by an axial piston motor. The internal ring gear has a grease cavity for pinion. The swing bearing is a single-row shear type ball bearing. Dual stage relief valves are used for smooth swing deceleration and stops. A mechanical disc swing brake is included.

| SH80BS-7 | |
|-------------------|----------------------------|
| Swing speed | 0 - 10.4 min ⁻¹ |
| Tail swing radius | 1,680 mm |
| Swing torque | 17 kN·m |

Undercarriage

An X-style carbody is integrally welded for strength and durability. The grease cylinder track adjusters have shock absorbing springs. The undercarriage has lubricated rollers and idlers.

Type of shoe: sealed link shoe

Upper rollers -

Heat treated, mounted on steel bushings with leaded tin bronze casting, sealed for lifetime lubrication.

Lower rollers -

Heat treated, mounted on steel bushings with leaded tin bronze casting, sealed for lifetime lubrication.

Track adjustment -

Idle axles adjusted with grease cylinder integral with each side frame; adjustment yoke mechanism fitted with heavy duty recoil spring.

Number of rollers and shoes on each side

| SH80BS-7 | |
|---------------|----|
| Upper rollers | 1 |
| Lower rollers | 5 |
| Track shoes | 39 |

Travel system

Two-speed independent hydrostatic system with compact axial motors for increased performance. Hydraulic motor powered output shaft coupled to a planetary reduction unit and track sprocket. All hydraulic components mounted within the width of side frame. Travel speed can be selected by the switch panel on the monitor display. Hydraulically released disc parking brake is built into each motor.

| SH80BS-7 | | |
|--------------|-------|----------|
| Travel speed | High | 5.1 km/h |
| | Low | 3.2 km/h |
| Drawbar pull | 59 kN | |

Lubricant & coolant capacity

| SH80BS-7 | |
|-----------------------------|---------|
| Hydraulic system | 96 ltr |
| Hydraulic oil tank | 51 ltr |
| Fuel tank | 120 ltr |
| Cooling system | 12 ltr |
| Final drive case (per side) | 1.1 ltr |
| Engine crank case | 12 ltr |

Auxiliary hydraulic system

| SH80BS-7 | | | |
|--------------------------------|-------------|---------------------------------------|------------------------------|
| Auxiliary piping type (option) | For Breaker | For Double (breaker & crusher) acting | For D/A + Second option line |
| Arm type | Reinforced | Reinforced | Reinforced |
| Bucket linkage type | HD | HD | HD |
| Auxiliary hydraulic pump flow | 74 ltr/min | 148 ltr/min | 148+35 ltr/min |

Specifications

Bucket

Options and specifications may differ depending on countries and regions

| Model | | SH80BS-7 | |
|---------------------------------------|---------------------|---------------------|---------------------|
| Bucket capacity (ISO/SAE/PCSA heaped) | | 0.28 m ³ | 0.34 m ³ |
| Bucket type | | STD | STD |
| Number of teeth | | 4 | 4 |
| Width | With side cutter | 804 mm | 934 mm |
| | Without side cutter | 730 mm | 860 mm |
| Weight | | 206 kg | 223 kg |
| Combination | 1.69 m arm | ● | ○ |
| | 2.19 m arm | △ | × |

● Standard bucket (Suitable for materials with density up to 1,800 kg/m³ or less)

○ Suitable for materials with density up to 1,600 kg/m³ or less

△ Suitable for loading

× Not available

Weight & ground pressure

| Model | | SH80BS-7 | | |
|---------------------|------------|---------------|------------------|-----------------|
| Shoe type | Shoe width | Overall width | Operating weight | Ground pressure |
| Triple grouser shoe | 450 mm | 2,320 mm | 8,720 kg | 39 kPa |

Digging force

| Model | | SH80BS-7 | |
|----------------------|----------|----------|--------|
| Arm length | | 1.69 m | 2.19 m |
| Bucket digging force | ISO 6015 | 57 kN | 57 kN |
| Arm digging force | ISO 6015 | 40 kN | 34 kN |

Lifting Capacity

- Notes: 1. Ratings are based on ISO 10567
 2. Lifting capacity does not exceed 75% of tipping load with the machine on firm, level ground or 87% full hydraulic capacity.
 3. The load point is arm top.
 4. *Indicates load limited by hydraulic capacity.
 5. 0 m = Ground.

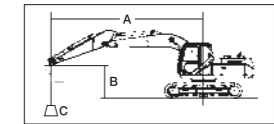

Unit: kg

SH80BS-7

SHOE : 450 (mm) G
 MAXIMUM REACH : 7.07 (m)
 ARM LENGTH : 1.69 (m)
 COUNTERWEIGHT : 1,060 (kg)
 BOOM : 3.50 (m)

| Arm Top Height | Max. Radius | | 6 m | | 5 m | | 4 m | | 3 m | | 2 m | | Min. Radius | | | | | |
|----------------|-------------|------|-------|------|-------|-------|-------|-------|--------|--------|--------|--------|-------------|--------|--------|------|--------|------|
| | Icon | Icon | Icon | Icon | Icon | Icon | Icon | Icon | Icon | Icon | Icon | Icon | Icon | Icon | | | | |
| | (kg) | (m) | (kg) | (m) | | | | | | | | | (kg) | (m) | (kg) | (m) | | |
| 5 m | 2 030* | 4.43 | 1 900 | 4.43 | | | | | 2 050* | 2 050* | | | | | 2 050* | 3.97 | 2 050* | 3.97 |
| 4 m | 1 570 | 5.26 | 1 440 | 5.26 | | | 1 710 | 1 570 | 2 070* | 2 070* | | | | | 2 070* | 3.88 | 2 070* | 3.88 |
| 3 m | 1 350 | 5.75 | 1 240 | 5.75 | | | 1 690 | 1 550 | 2 380 | 2 160 | 3 100* | 3 100* | | | 2 810* | 3.35 | 2 810* | 3.35 |
| 2 m | 1 250 | 5.99 | 1 150 | 5.99 | | | 1 640 | 1 500 | 2 270 | 2 060 | | | | | 3 270 | 3.13 | 2 920 | 3.13 |
| 1 m | 1 220 | 6.03 | 1 120 | 6.03 | 1 230 | 1 130 | 1 590 | 1 450 | 2 180 | 1 970 | | | | | 2 980 | 3.22 | 2 660 | 3.22 |
| 0 m | 1 260 | 5.86 | 1 150 | 5.86 | | | 1 560 | 1 420 | 2 120 | 1 920 | 3 190* | 2 910 | | | 3 140* | 2.99 | 2 930 | 2.99 |
| -1 m | 1 380 | 5.46 | 1 260 | 5.46 | | | 1 550 | 1 410 | 2 110 | 1 910 | 3 290 | 2 910 | 3 130* | 3 130* | 2 910* | 1.55 | 2 910* | 1.55 |
| -2 m | 1 670 | 4.77 | 1 520 | 4.77 | | | | | 2 130 | 1 930 | 3 320 | 2 950 | 5 470* | 5 470* | 4 940* | 1.59 | 4 940* | 1.59 |
| -3 m | 2 380* | 3.55 | 2 360 | 3.55 | | | | | | | 3 040* | 3 040 | | | 3 590* | 2.55 | 3 590* | 2.55 |

SH80BS-7

SHOE : 450 (mm) G
 MAXIMUM REACH : 7.53 (m)
 ARM LENGTH : 2.19 (m)
 COUNTERWEIGHT : 1,060 (kg)
 BOOM : 3.50 (m)

| Arm Top Height | Max. Radius | | 6 m | | 5 m | | 4 m | | 3 m | | 2 m | | Min. Radius | | | | | |
|----------------|-------------|------|-------|------|-------|-------|-------|-------|--------|--------|-------|-------|-------------|--------|--------|------|--------|------|
| | Icon | Icon | Icon | Icon | Icon | Icon | Icon | Icon | Icon | Icon | Icon | Icon | Icon | Icon | | | | |
| | (kg) | (m) | (kg) | (m) | | | | | | | | | (kg) | (m) | (kg) | (m) | | |
| 5 m | 1 610* | 5.09 | 1 550 | 5.09 | | | 1 740 | 1 590 | | | | | | | 1 710* | 4.47 | 1 710* | 4.47 |
| 4 m | 1 360 | 5.81 | 1 250 | 5.81 | | | 1 740 | 1 600 | | | | | | | 1 720* | 4.40 | 1 720* | 4.40 |
| 3 m | 1 200 | 6.24 | 1 100 | 6.24 | 1 280 | 1 180 | 1 710 | 1 570 | 2 070* | 2 070* | | | | | 2 090* | 3.89 | 2 090* | 3.89 |
| 2 m | 1 120 | 6.47 | 1 030 | 6.47 | 1 260 | 1 160 | 1 650 | 1 520 | 2 310 | 2 100 | | | | | 3 500 | 3.06 | 3 130 | 3.06 |
| 1 m | 1 090 | 6.50 | 1 000 | 6.50 | 1 230 | 1 130 | 1 600 | 1 460 | 2 200 | 1 990 | | | | | 3 200 | 3.10 | 2 850 | 3.10 |
| 0 m | 1 120 | 6.34 | 1 020 | 6.34 | 1 210 | 1 100 | 1 550 | 1 420 | 2 130 | 1 920 | 3 270 | 2 900 | | | 3 110 | 3.10 | 2 760 | 3.10 |
| -1 m | 1 200 | 5.99 | 1 100 | 5.99 | | | 1 530 | 1 390 | 2 090 | 1 890 | 3 250 | 2 880 | 2 620* | 2 620* | 2 680* | 2.06 | 2 680* | 2.06 |
| -2 m | 1 390 | 5.38 | 1 270 | 5.38 | | | 1 530 | 1 400 | 2 100 | 1 890 | 3 270 | 2 900 | 4 270* | 4 270* | 3 520* | 1.07 | 3 520* | 1.07 |
| -3 m | 1 880 | 4.39 | 1 710 | 4.39 | | | | | 2 140 | 1 930 | 3 330 | 2 960 | 6 570* | 6 080 | 5 940* | 1.66 | 5 940* | 1.66 |

Principle Specifications

| | | SH80BS-7 |
|------------------|------------------------------|---|
| | | STD Specifications |
| Base | Boom length | 3.50 m |
| | Arm length | 1.69 m |
| | Bucket capacity (ISO heaped) | 0.28 m ³ |
| | Std. operating weight | 8,720 kg |
| Engine | Make & model | YANMAR 4TNV98CT |
| | Rated output | 50.7 kW/2,000 min ⁻¹ |
| Hydraulic System | Displacement | 3,318 ltr |
| | Main pump | 2 variable displacement axial piston pumps with regulating system |
| | Max. pressure | 29.4 MPa |
| | Travel motor | Variable displacement axial piston motor |
| | Parking brake type | Mechanical disc brake |
| Performance | Swing motor | Fixed displacement axial piston motor |
| | Travel speed | 5.1/3.2 km/h |
| | Drawbar pull | 59 kN |
| | Gradeability | 70% <35°> |
| | Ground pressure | 39 kPa |
| | Swing speed | 10.4 min ⁻¹ |
| | Bucket digging force | 57 kN |
| Others | Arm digging force | 40 kN |
| | Fuel tank | 120 ltr |
| | Hydraulic fluid tank | 51 ltr |

Working Range

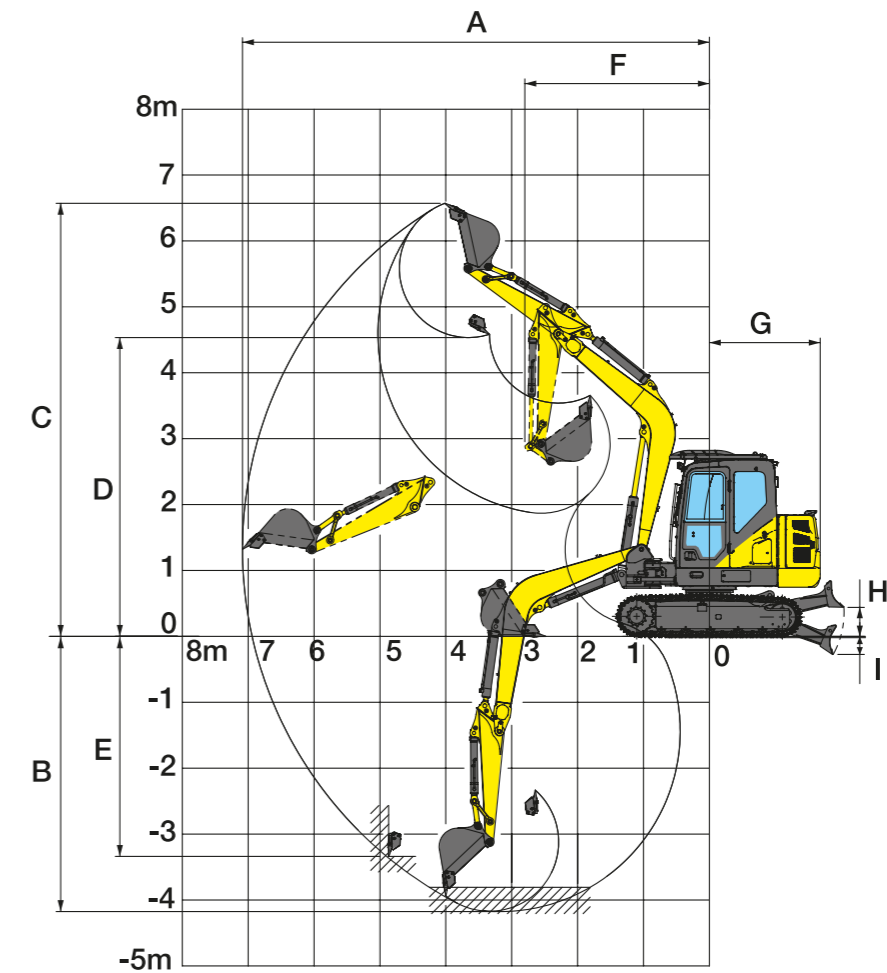

| | | SH80BS-7 | |
|--------------------------------|--|----------|----------|
| Arm length | | 1.69 m | 2.19 m |
| Boom length | | 3.50 m | |
| A Max. digging radius | | 7,090 mm | 7,560 mm |
| B Max. digging depth | | 4,180 mm | 4,670 mm |
| C Max. digging height | | 6,570 mm | 6,890 mm |
| D Max. dumping height | | 4,530 mm | 4,850 mm |
| E Max. vertical wall cut depth | | 3,340 mm | 3,920 mm |
| F Min. front swing radius | | 2,800 mm | 3,040 mm |
| G Rear end swing radius | | 1,680 mm | |
| H Max. lift above ground | | 440 mm | |
| I Min. drop below ground | | 275 mm | |

Standard Equipment

[Hydraulic system]

- SIH: S a hydraulic system
- Operation mode (SP, H and A mode)
- Automatic 2-speed travel
- Boom holding valve
- Arm reactivation circuit
- Automatic swing parking system
- Auxiliary valve
- High-performance return filter

[Cabin/interior equipment]

- 4-point fluid mounts
- New full-colour LCD monitor
- Fresh-air intake pressurised full-automatic air conditioner
- Defroster
- High water-repellent seat
- Seat suspension
- Armrest & headrest
- Windscreen wiper (with intermittent operation function)
- Cup holder
- Magazine rack
- Accessory case
- Floor mat
- Ashtray & cigarette lighter
- Cab light (Auto-OFF function)
- Coat hook
- Operation lever with one-touch wiper switch
- Polycarbonate roof top window with sunshade

[Safety equipment]

- ROPS cab (FOPS level 1)
- Head guard (OPG Level 2)
- Rear/right side camera
- Rearview mirror (left/right)
- Emergency escape tool
- Retracting seat belt
- Gate lock lever (engine neutral start)
- Travel alarm
- Anti-theft alarm system
- Engine room firewall
- Fan guard
- Engine emergency stop switch

[Others]

- Auto/one-touch idling
- Auto idle shutdown system
- EMS
- Long-life hydraulic oil
- Two lights (right of boom, cab)
- Fuel filter (with water separator)
- Fuel pre-filter (with water separator)
- Double-element air cleaner
- Grease-enclosed track link
- Large tool box
- A set of tools

Accessories (option)

■ Cab-top lights (LED)



■ Camera lights (LED) (left rear, right rear)



■ Front mesh guard (full)



■ Sun visor



■ Front guard (OPG level 1 or 2)



■ Refuel pump

■ Hose burst check valve (HBCV) for boom/arm cylinders

Accessories and specifications may differ depending on countries and regions.

Dimensions

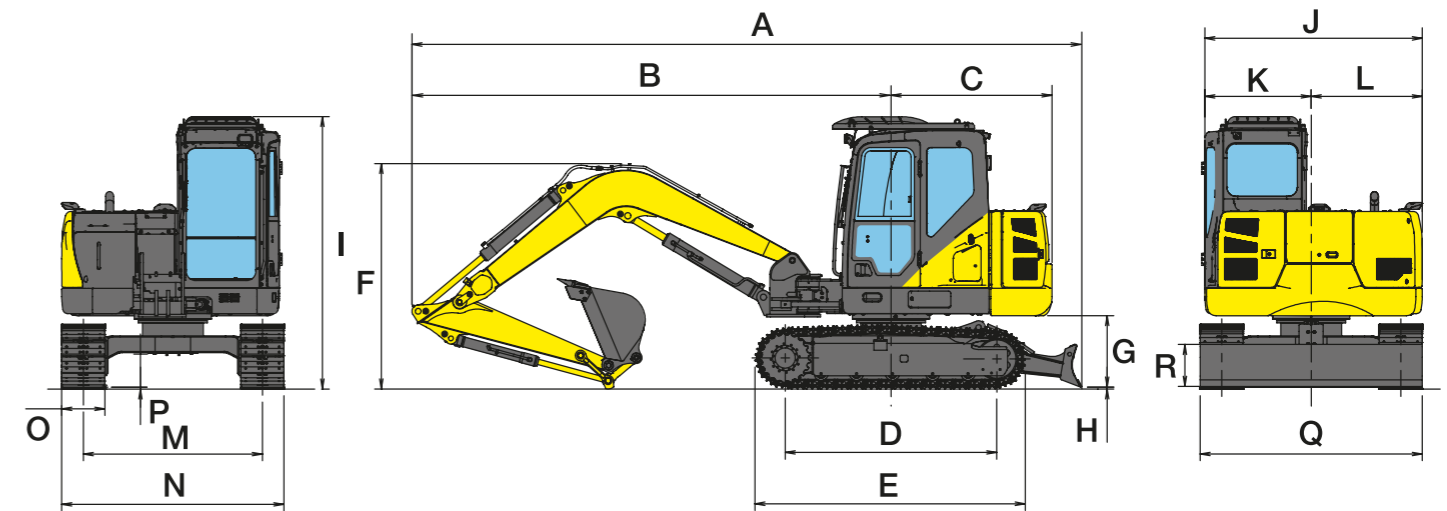

| Model | SH80BS-7 | |
|---|----------|----------|
| Arm length | 1.69 m | 2.19 m |
| A Overall length | 6,990 mm | 7,040 mm |
| B Length from centre of machine (to arm top) | 5,000 mm | 5,050 mm |
| C Length from centre of machine (to rear end) | | 1,680 mm |
| D Centre to centre of wheels | | 2,210 mm |
| E Overall track length | | 2,845 mm |
| F Height to top of boom | 2,350 mm | 2,760 mm |
| G Clearance height under upper structure | | 745 mm |
| H Shoe lug height | | 20 mm |
| I Overall height (to top of cab) | | 2,840 mm |
| J Upper structure overall width | | 2,270 mm |
| K Width from centre of machine (left side) | | 1,110 mm |
| L Width from centre of machine (right side) | | 1,160 mm |
| M Track gauge | | 1,870 mm |
| N Overall width | | 2,320 mm |
| O Std. shoe width | | 450 mm |
| P Minimum ground clearance | | 345 mm |
| Q Width of blade | | 2,320 mm |
| R Height of blade | | 450 mm |